

CALL STACKER V-5325150

INTRODUCTION

The Digital Voice Announcer Call Stacker is a microprocessor based audio recording and announcement system. The Call Stacker is used in conjunction with a paging system to provide buffered announcement play to the paging system.



SPECIFICATIONS (also see Table 3)

FEATURES

- Maximum Record Time - 3 Minutes
- Maximum of 30 Announcements
- Announcement Verification
- 5 Analog Station Port Input Channels
- Battery Backup for up to 2 Hours
- Rack Mountable - 19" (48.3cm)
- Pause Override Control
- Provides Audio Output and a Contact Closure

Power Requirements

- 115 Vac, 60 Hz

Environment

- Temperature: 0 to 40°C (32 to 104°F)
- Humidity: 5 to 95%

Dimensions/Weight

- 16.25"W x 1.75"H x 9.25"D
(41.28cm x 4.45cm x 23.50cm)
- 13.0 lbs (5.85 kg)
- 19"W (48.3cm) with rack brackets

OPERATION

The Call Stacker features 5 Input Station (recording) channels, a single Page Output channel and 3 minutes of recording time.

Up to 5 announcements can be recorded simultaneously, virtually eliminating frustrating delays encountered when accessing the paging system. The recorded announcements are queued in order so the first complete announcement recorded, plays first, followed by the second announcement, etc. The Call Stacker allows users to verify their announcements before they play to the paging system. If a user is not content with their recorded announcement, they can re-record it repeatedly until they are satisfied.

The Call Stacker's Page Output channel interfaces to the paging system's control unit. Once an announcement is recorded, the Call Stacker plays the announcement over the Page Output channel to the paging system. While the recorded announcement is playing, the Page Output channel provides a contact closure to the paging system.

Once the complete recorded announcement plays to the paging system, it is erased from the Call Stacker, freeing up the recording time for new announcements.

The Call Stacker can be configured to record and play back paging zone selection signals. Between 2 and 4 DTMF digits can be entered prior to recording an announcement which, upon output, precede the recorded announcement and select the paging system's paging zone.

NOTE: Associated equipment would need to be powered by an uninterruptible power supply. The Call Stacker is equipped with battery backup which allows it to operate for up to two hours, from a fully charged battery, if a power failure occurs.

INSTALLATION

1. Attach the reversible 19/23" brackets to the Call Stacker using the 6-32 x 3/8" screws provided, then secure the Call Stacker to a back board or into an equipment rack.

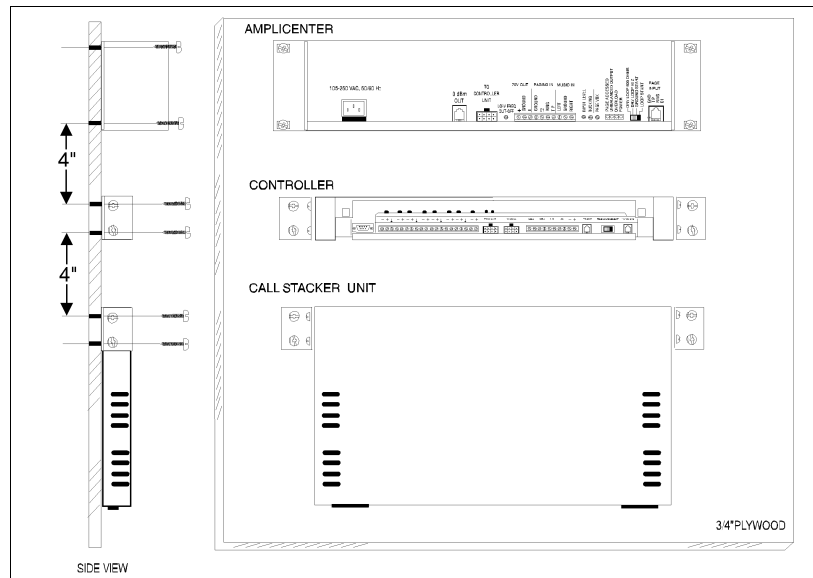

Figure 1. Wall Mounted Unit

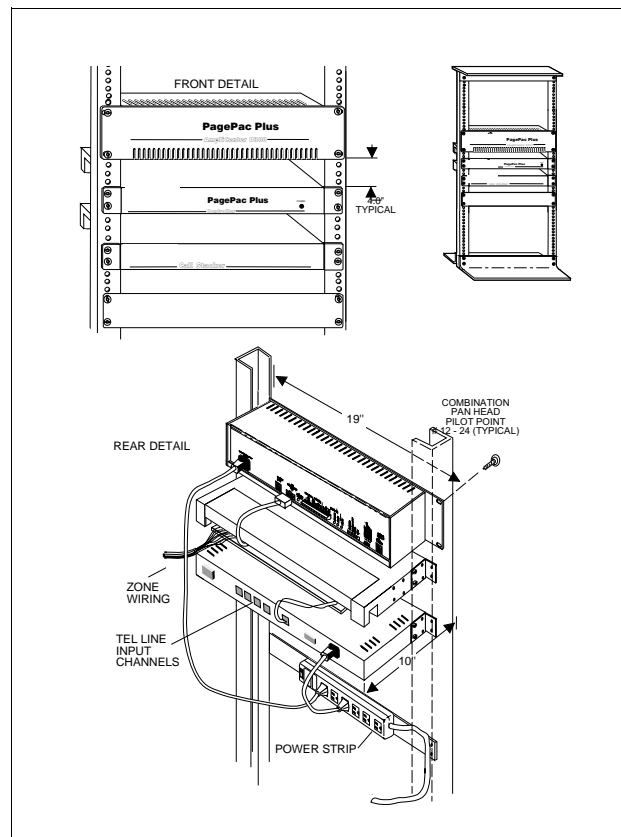

Figure 2. Rack Mounted Unit

- Set the option switch on the Call Stacker (see Figure 5) for the desired system configuration (refer to Table 1).

Table 1. Option Switch Setting

	SET SWITCH # 1 TO	SET SWITCH # 2 TO	SET SWITCH # 3 TO	SET SWITCH # 4 TO	SET SWITCH # 5 TO	SET SWITCH # 6 TO	SET SWITCH # 7 TO
Number of DTMF Digits in Zone Code							
0	ON	ON	—	—	—	—	—
2	OFF	ON	—	—	—	—	—
3	ON	OFF	—	—	—	—	—
4	OFF	OFF	—	—	—	—	—
Voice Prompts							
None	—	—	ON	ON	—	—	—
English only	—	—	OFF	ON	—	—	—
Spanish only	—	—	ON	OFF	—	—	—
English/Spanish	—	—	OFF	OFF	—	—	—
Length of Recording Cut Off (when user hangs up during recording)							
None	—	—	—	—	ON	ON	—
0.25 sec	—	—	—	—	OFF	ON	—
0.50 sec	—	—	—	—	ON	OFF	—
0.75 sec	—	—	—	—	OFF	OFF	—
Confirmation or Pre-Announcement Tone							
2 Second Delay	—	—	—	—	—	—	SEE NOTE

NOTE: When switch #7 is “OFF”, there will be no delay in time from when the paging system zone is accessed until the time when the message is sent. When switch #7 is “ON”, there will be a 2 second delay from when the paging system/zone is accessed until the time when the message is sent. The delay is installed in order for a Confirmation/Pre-announcement tone (if available or optioned) to be played over the system before the message is sent.

- Connect the Call Stacker to the paging system (see Figure 4):
 - Connect the Call Stacker's Pause Override Control input to the attendant override (attendant access control leads) or incoming alarm signal from the paging system.
 - Connect one or more of the Call Stacker's Input Station channels to PBX/KTS analog station inputs on the telephone system through FCC/DOC approved modular jacks. Connect the Call Stacker's Page Output channel to the paging system as shown in Figures 4 and 5 through an FCC/DOC approved modular jack. The control contact signal is used to secure and release the paging system controller.

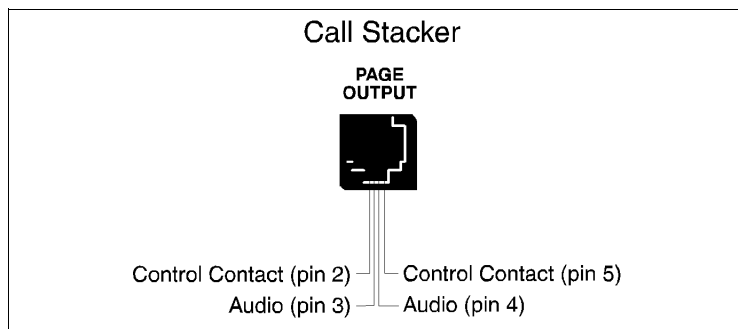

Figure 3. Page Output Channel Connection of Call Stacker

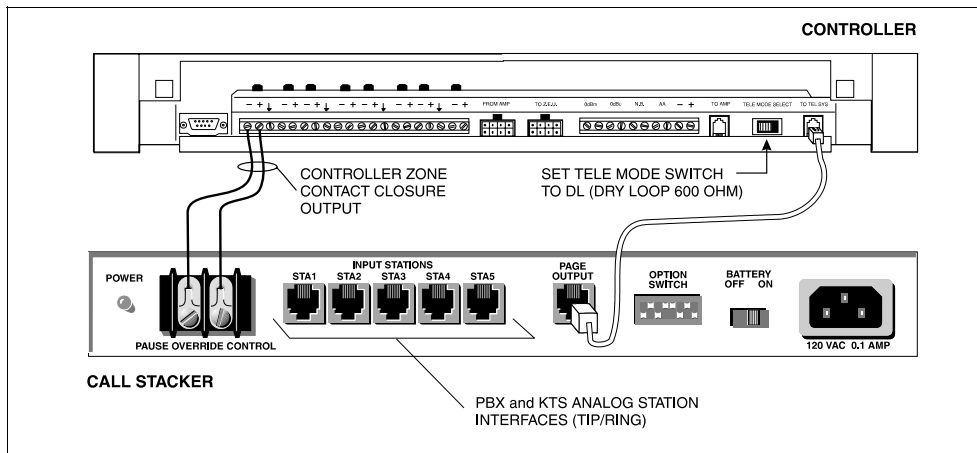

Figure 4. Connection to Paging System

NOTE: The zone contact closure output must be programmed as a Zone Output type “AA READY” if the Attendant Access input is used.

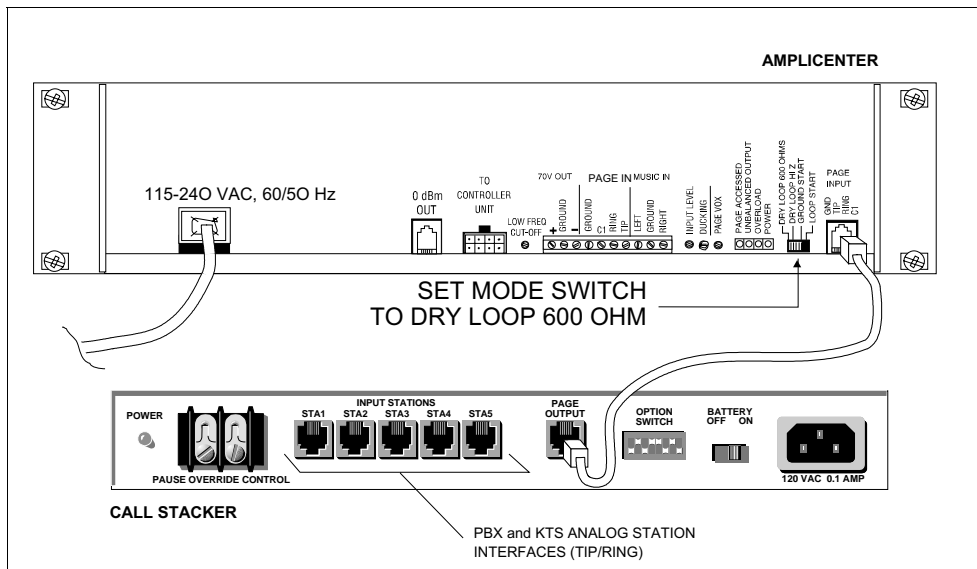

Figure 5. Connection to AmpliCenter (Optional)

NOTE: The connection to the AmpliCenter depicted in Figure 5 is used instead of a connection directly to the Controller.

NOTE: PBX and KTS stations must have the ability to send a forward disconnect to the Call Stacker's Station inputs.

4. Connect the detachable power supply cord to a 110/120 VAC outlet and the Call Stacker and verify the Power LED illuminates.
5. Turn the battery switch **ON**.

CONTROLS AND INDICATORS

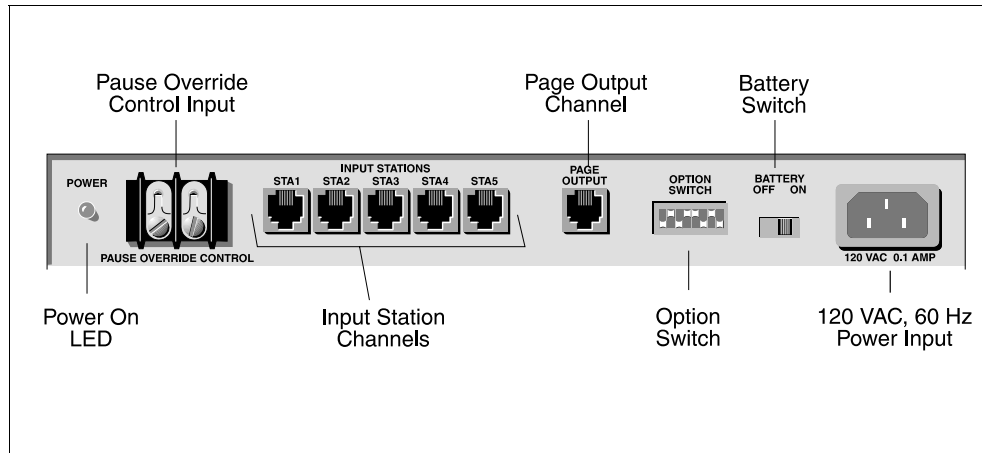

Figure 6. Rear Panel Detail

Table 2. Rear Panel Description

ITEM	DESCRIPTION
Power On LED	Illuminates when power is supplied to the Call Stacker.
Pause Override Control Input	Enables/disables the Page Output channel. When a contact closure (a short) between the two terminals is detected, the Call Stacker terminates the outgoing announcement (if any), requeues it and disables the Page Output channel. When the contact closure is removed, the Page Output channel is re-enabled and the terminated announcement plays to the paging system in its entirety (see note below).
Input Station (record) Channels	PBX and KTS analog station interfaces (tip/ring pairs) to the Public Telephone Network, a PABX or a Key System.
Page Output Channel	Audio and control contact signals to the paging system as shown in figure 6. Between outgoing announcements the control contact opens for a minimum of 250 msec. to release the paging system controller.
Option Switch	See table 1.
Battery Switch	Enables/disables battery backup. Turn the switch ON to enable the battery backup.
Power Input	110/120 VAC, 60Hz, power input
NOTE: The Input Station channels continue to operate when a contact closure is detected. Recorded announcements are held in a queue and play out sequentially (first in, first out) when the contact closure is removed.	

RECORDING ANNOUNCEMENTS

VOICE PROMPTS ENABLED

1. Dial up the input station connected to the Call Stacker. The Call Stacker answers the station and responds “Enter zone code (Marque el código de la zona)”. Proceed to step 2.
2. Enter a DTMF tone sequence using the telephone keypad to select a paging zone.
 - Once the required number of DTMF digits (see Table 1) are entered, the Call Stacker responds “Start recording, press the pound key to end or hang up (Empiece a grabar el mensaje, para terminar la grabación cuelge o marque la tecla de numero)” followed by a high tone. Proceed to step 3.

NOTE: If the number of digits in the paging zone is set to 0 (see Table 1), the Call Stacker answers the station and responds “Start recording, press the pound key to end or hang up (Empiece a grabar el mensaje, para terminar la grabación cuelge o marque la tecla de numero)” followed by a high tone. Skip step 2 and proceed to step 3.

Important: If all the recording time is used up, the Call Stacker answers the station and responds with “No recording time available (No hay tiempo de grabación disponible)” or “Message not recorded (No hay mensajes grabados)” then disconnects. If this occurs wait a few seconds before re-attempting to record the announcement.

3. Record the announcement. To end recording, either:
 - Hang up to enter the recorded announcement into the queue, or
 - Press the “#” key to hear the recorded announcement. The Call Stacker responds “Hang up if finished, press zero to re-record or stay on the line to review your message (Cuando termine de grabar cuelge, marque la tecla cero para regrabar, o siga en la linea para escuchar el mensaje grabado)”, plays back the recorded announcement and then responds “Hang up if finished, press zero to re-record (Cuando termine de grabar cuelge, marque la tecla cero para regrabar)”. Press the “0” key to re-record the announcement and return to step 2 or hang up to accept the announcement and enter it into the queue.

NOTE: Press the “#” key while the voice prompts are playing to interrupt (and skip) them

VOICE PROMPTS DISABLED (Switch 3 & 4 ON)

1. Dial up the input station connected to the Call Stacker and wait for the Call Stacker to answer the station and respond with a high tone. Proceed to step 2.

NOTE: If the number of digits in the paging zone code is set to 0 (see Table 1), skip step 2 and proceed to step 3.

2. Enter a DTMF tone sequence using the telephone keypad to select a paging zone. Once the required number of DTMF digits (see Table 1) are entered, the Call Stacker responds with a high tone. Proceed to step 3.
3. Record the announcement. To end recording, either:
 - Hang up to enter the recorded announcement into the queue, or

- Press the “#” key to hear the recorded announcement. The Call Stacker responds with a high tone, plays back the recorded announcement and then responds with a second high tone. Press the “0” key to re-record the announcement and return to step 2 or hang up to accept the announcement and enter it into the queue.

Important: If all the recording time is used up, the Call Stacker responds with two consecutive low tones then disconnects. If this occurs your announcement has not been recorded. Wait a few seconds before re-attempting to record the announcement.

ANNOUNCEMENT PLAYBACK

Once a recorded announcement is entered into the queue, the Call Stacker immediately closes the control contact on the Page Output channel to access the paging system controller.

The Call Stacker then plays out the recorded DTMF sequence to select the paging zone followed by the recorded announcement.

At the end of the announcement the Call Stacker erases the announcement and opens the control contact on the Page Output channel to release the paging system controller.

NOTE: If more than one announcement is in the queue, the control contact remains open for a minimum of 250 msec.

Important: If at any time a contact closure is detected on the Pause Override Control Input, the Call Stacker immediately terminates the outgoing announcement and requeues it for playback in its entirety once the contact closure is removed.

SPECIFICATIONS

Table 3. Call Stacker Unit Specifications

SPECIFICATION	DESCRIPTION
Recording Time	3 minute base unit.
Input Lines	5 analog station ports.
Output Lines	1 page output channel.
Number of stacked Announcements	30 individual announcements.
Altitude:	Sea level to 10,000 ft. operational (1048 to 648 millibars) 40,000 ft. max. shipment.
Environmental	Locate in an area free of excess moisture, corrosive gases, dust, and chemicals.
Battery Backup	Allows up to two hours of operation during a power failure. Total charge time 48 hours.
Frequency Response	200 Hz to 3.4 kHz (±3 dB).
Output Level	-9 dBm.
Control Contact Rating	0.3 A / 60 VDC 1.0 A / 24 VDC 0.5 A / 120 VAC

TECHNICAL ASSISTANCE

When calling, have a VOM and a telephone test set available and call from the job site. Call (540) 427-3900 and ask for PagePac Technical Support, or call (540) 427-6000 for Valcom 24-hour Automated Support or visit our websites at <http://www.pagepac.com> and www.valcom.com.

Should repairs be necessary, attach a tag to the unit clearly stating company name, address, phone number, contact person, and the nature of the problem. Send the unit to:

**Valcom, Inc.
PagePac® Repair Dept.
5614 Hollins Road
Roanoke, VA 24019-5056**

FCC

This equipment complies with Part 68 of the FCC rules. On the rear of the digital voice announcer is a label that contains, among other information, the FCC registration number and ringer equivalence number (REN) for this equipment. If requested, this information must be provided to the telephone company.

The USOC for this equipment is RJ11C. The facility interface code is 02LS2 and the service order code is 9.0F. This equipment is hearing aid compatible.

The ringer equivalence number (REN) is used to determine the quantity of devices which may be connected to the telephone line. Excessive REN's on the telephone line may result in the devices not ringing in response to an incoming call. In most, but not all areas, the sum of the REN's should not exceed five (5.0). To be certain of the number of devices that may be connected to the line, as determined by the total REN's contact the telephone company to determine the maximum REN for the calling area.

If the digital voice announcer causes harm to the telephone network, the telephone company will notify you in advance that temporary discontinuance of service may be required. But if advance notice isn't practical, the telephone company will notify the customer as soon as possible. Also, you will be advised of your right to file a complaint with the FCC if you believe it is necessary.

The telephone company may make changes in its facilities, equipment, operations, or procedures that could affect the operation of the equipment. If this happens, the telephone company will provide advance notice in order for you to make the necessary modifications in order to maintain uninterrupted service.

This equipment cannot be used on public coin service provided by the telephone company. Connection to Party Line Service is subject to state tariffs. Contact the state public utility commission, public service commission or corporation commission for information.

FCC Registration Number: F4PCAN-20988-AN-N

Ringer Equivalence Number: 0.7B(ac); 2.6(dc)

DOC

The Canadian Department of Communications label identifies certified equipment. This certification means that the equipment meets certain telecommunications network protective, operational and safety requirements. The Department does not guarantee that the equipment will operate to the user's satisfaction.

Before installing this equipment, users should ensure that it is permissible to be connected to the facilities of the local telecommunications company. The equipment must also be installed using an approved method of connection. In some cases, the company's inside wiring associated with a single line individual service may be extended by means of a certified jack-plug-cord ensemble (telephone extension cord). The customer should be aware that compliance with the above conditions may not prevent degradation of service in some situations. Existing telecommunications company requirements do not permit their equipment to be connected to customer-provided jacks, except where specified by individual telecommunications company tariffs.

Repairs to certified equipment should be made by an authorized Canadian maintenance facility designated by the supplier. Any repairs or alterations made by the user to this equipment, or equipment malfunctions, may give the telecommunications company cause to request the user to disconnect the equipment.

Users should ensure for their own protection that the electrical ground connections of the power utility, telephone lines and internal metallic water pipe system, if present, are connected together. This precaution may be particularly important in rural areas.

Caution: Users should not attempt to make such connections themselves, but should contact the appropriate electrical inspection authority, or electrician, as appropriate.

DOC Certification Number: 5576106A

Load Number: 26

The Load Number (LN) assigned to each terminal device denotes the percentage of the total load to be connected to a telephone loop which is used by the device, to prevent overloading. The termination on a loop may consist of any combination of devices subject only to the requirement that the total of the Load Numbers of all the devices does not exceed 100.

NOTE: This digital apparatus does not exceed the Class A limits for radio noise emission from digital apparatus set out in the radio interference regulations of the Canadian Department of Communications.