

## V-1080 FLEXHORN THREE WATT ONE-WAY PAGING HORN

### INTRODUCTION

The Valcom V-1080 Flexhorn is a one-way self-amplified paging horn designed to provide voice paging as well as background music. This horn is weatherproof and can be used indoors or outside in environments ranging from -20 to +55°C. A volume control is accessible on the front of the cone. The horn is offered in gray, beige and white.

Model V-1080-GY	Gray
Model V-1080-BG	Beige
Model V-1080-W	White



### Dimensions/Weight

- 6.80"H x 8.30"W x 3.30"D  
(17.27cm H x 21.08cm W x 8.38cm D)
- 2.1 lbs. (0.95 kg)

The V-1080 requires -24VDC, 150mA (3 Valcom Power Units) and is FCC Part 68 Registered under BAFUSA-69358-KX-N.

### CONNECTIONS

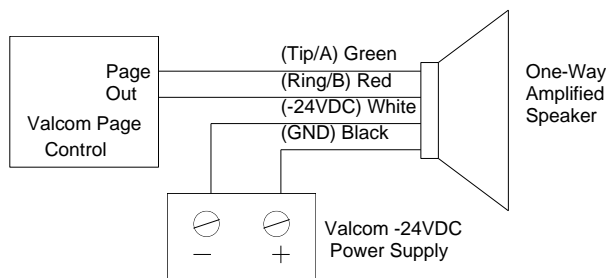

**NOTE: Do not connect this speaker directly to a 25/70/100 Volt amplifier as damage to both the amplifier and speaker may occur. A V-1095 can be used to provide an interface between a centrally amplified speaker line and Valcom self-amplified horns.**

### POWER WIRE RUN

# Horns per Power Run	Wire Run Length (feet)	
	24 AWG	22 AWG
<b>V-1080 (3 Watts)</b>		
5	250	400
2	500	800
1	760	1200

### MOUNTING INSTRUCTIONS

#### FLUSH MOUNT

Using the template packaged with the speaker, draw the speaker outline on the wall to be cut. Make appropriate wiring connections and test the speaker for operation. Using appropriate mounting screws (not furnished) drill and mount the flange as shown.

#### UNIVERSAL BRACKET

Loosen or separate the universal bracket leaves by loosening or removing the handle and hardware. Using the back leaf as a template, mark the wall through the mounting holes, drill and mount to the wall using appropriate screws (not furnished) or mount directly to a junction box.

Mount the T-bracket to the back of the horn as shown using the (2) ½ inch screws provided.

**"C" CLAMP FOR "I" BEAM MOUNTING**

A "C" clamp is provided with the horns to allow mounting to a beam. Place the bolt through the hole in the bottom of the base to secure the "C" clamp to the beam. It is suggested that the horn be mounted to the underside of the "I" beam to provide maximum positioning adjustments. Mount "C" clamp with (2) ½ inch screws provided.

Assistance in troubleshooting is available from the factory. When calling, you should have a VOM and a test set and call from the job site. Call (540) 563-2000 and press 1 for Technical Support or visit our website at <http://www.valcom.com>.

Valcom equipment is not field repairable. Valcom, Inc. maintains service facilities in Roanoke, VA. Should repairs be necessary, attach a tag to the unit clearly stating company name, address, phone number, contact person and the nature of the problem. Send the unit to:

**Repair and Return Dept.  
Valcom, Inc.  
5614 Hollins Road  
Roanoke, VA 24019-5056**

**TECHNICAL ASSISTANCE**

When trouble is reported, verify the unit is properly connected and there are no broken connections leading to this unit. Ascertain volume control is turned up.

<b>TROUBLESHOOTING CHART</b>	
<b>PROBLEM</b>	<b>PROBABLE CAUSE AND CORRECTION</b>
No Sound	<ul style="list-style-type: none"> <li>- Check volume control turned up (clockwise).</li> <li>- Check presence and polarity of -24VDC and GND.</li> <li>- Using a telephone test set, check for the proper audio level on the Tip and Ring leads and if necessary also at the source.</li> </ul>
Low Volume	<ul style="list-style-type: none"> <li>- Check volume control is turned up (clockwise).</li> <li>- Check voltage at the horn when in use, -20 to -24VDC required.</li> <li>- Using a telephone test set, check for proper audio level on Tip and Ring leads. It is possible that some low level audio will be heard with only one side of Tip and Ring connected.</li> </ul>
Loud Squeal	<ul style="list-style-type: none"> <li>- Lower volume of horn.</li> <li>- Aim horn in different direction.</li> <li>- Increase the distance between the telephone and horn.</li> <li>- Install a confidencer on the telephone in severe problem areas.</li> <li>- Add a V-9964, Stacking Feedback Eliminator.</li> </ul>

UNIVERSAL BRACKET

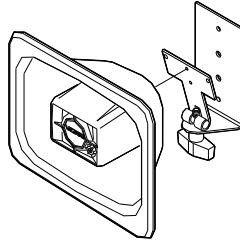

SURFACE MOUNTED WITH A UNIVERSAL MOUNTING BRACKET

"C" CLAMP FOR "I" BEAM MOUNTING

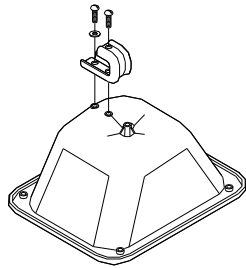

ATTACH CLAMP TO HORN

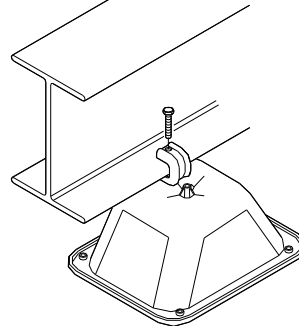

ATTACH FLEXHORN TO BEAM

USING MOUNTING SCREWS:

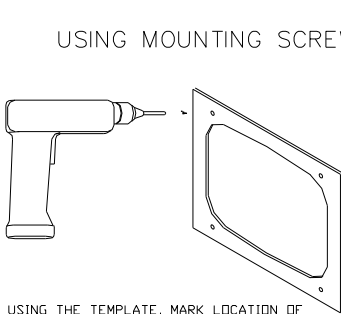

USING THE TEMPLATE, MARK LOCATION OF OPENING AND MOUNTING HOLES ON WALL. DRILL HOLES APPROPRIATE TO YOUR MOUNTING HARDWARE AND CUT OUT THE OPENING.

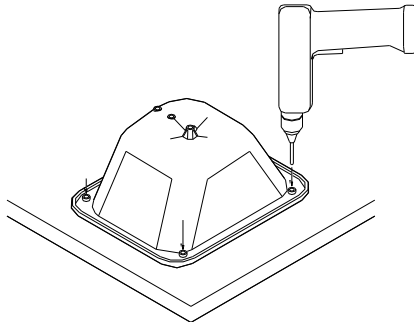

HOLDING FLEXHORN FIRMLY AGAINST A FLAT SURFACE, DRILL THROUGH EACH MOUNTING BOSS AS SHOWN

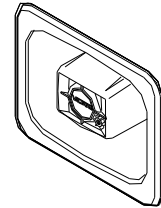

FLUSH MOUNTED IN A STUD WALL. INSTALLED WITH MOUNTING SCREWS OR CONSTRUCTION CEMENT

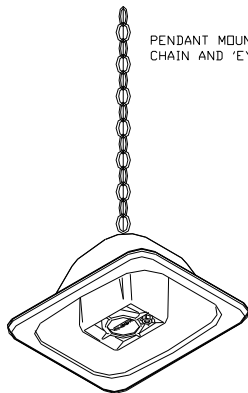

PENDANT MOUNTING WITH OPTIONAL CHAIN AND 'EYE' SCREW

OTHER MOUNTING OPTIONS:

- OPTIONAL V-9805 VANDAL RESISTANT ENCLOSURE (RECESS MOUNT)
- OPTIONAL V-9809 VANDAL RESISTANT ENCLOSURE (SURFACE MOUNT)

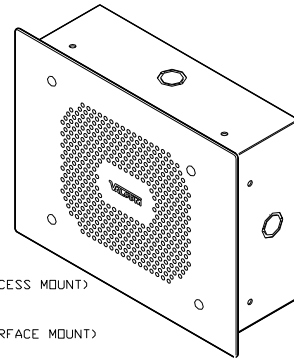

### VALCOM LIMITED WARRANTY

Valcom, Inc. warrants its products to be free from defects in materials and workmanship under conditions of normal use and service for a period of one year from the date of shipment. The obligation under this warranty shall be limited to the replacement, repair or refund of any such defective device within the warranty period, provided that:

1. inspection by Valcom, Inc. indicates the validity of the claim;
2. the defect is not the result of damage, misuse or negligence after the original shipment;
3. the product has not been altered in any way or repaired by others and that factory sealed units are unopened (a service charge plus parts and labor will be applied to units defaced or physically damaged);
4. freight charges for the return of products to Valcom are prepaid;
5. all units 'out of warranty' are subject to a service charge. The service charge will cover minor repairs (major repairs will be subject to additional charges for parts and labor).

**This warranty is in lieu of and excludes all other warranties, expressed or implied, and in no event shall Valcom, Inc. be liable for any anticipated profits, consequential damages, loss of time or other losses incurred by the buyer in connection with the purchase, operation or use of the product.**

This warranty specifically excludes damage incurred in shipment. In the event a product is received in damaged condition, the carrier should be notified immediately. Claims for such damage should be filed with the carrier involved in accordance with the F.O.B. point.

Headquarters:  
Valcom, Inc.  
5614 Hollins Road  
Roanoke, VA 24019-5056  
Phone: (540) 563-2000  
FAX: (540) 362-9800