

## V-2006A-E - INTEGRATED SIX ZONE PAGING CONTROL UNIT V-2006AHF-E - INTEGRATED SIX ZONE HANDSFREE TALKBACK PAGING CONTROL UNIT

**"WARNING: To reduce the risk of fire or electric shock, do not expose this equipment to rain or moisture."**

**"WARNING: Shock Hazard - Do Not Open."**

**"AVIS: Risque de Choc Electrique ne pas Ouvrir."**

**"PELIGRO: Corriente Electrica - No Abra."**

**"CAUTION: To reduce the risk of fire replace only with same type 2A, 125V fuse. 2A, 125V may be replaced by a 1A, 250V provided voltage selector is set for 230V."**

**"DANGER: Afin de réduire le risque de feu, remplacez le fusible par le même type de fusible à 2A, 125V. On peut utiliser un fusible à 1A, 250V pourvu que le sélecteur d'alimentation soit fixé sur 230V. Ne pas ouvrir."**

**"VORSICHT: Zur verringering von feuergefahr die sicherung nur mit derselben type 2A, 125V ersetzen. Statt 2A, 125V Kann 1A, 250V Benutzt werden, vorausgesetzt, die spannung ist auf 230V eingestellt. Nicht öffnen."**

**"PELIGRO: Para reducir el peligro de incendio remplazarlo unicamente con un fusible del mismo tipo 2A, 125V. El fusible de 2A, 125V podra ser remplazado por uno de 1A, 250V si el selector de voltaje esta puesto en 230V. No abres."**

### SPECIFICATIONS

#### Purpose

The V-2006A-E is an Integrated Six Zone Paging Control Unit. It provides six individual zones of one-way paging, plus three programmable zone groups and all call. The built-in -24 Vdc power supply provides 1.5 amps.

The V-2006AHF-E is an Integrated Six Zone Handsfree Talkback Paging Control Unit. It provides



six individual zones of talkback and/or one-way paging, plus three programmable zone groups and all call.

#### Nominal Specifications

- Zone Audio Outputs:
  - One-Way: Will supply audio for up to 150 Valcom one-way self-amplified speakers per zone
  - Handsfree: Will supply audio for up to 2 talkback speakers plus 40 one-way speakers per zone
- Input Impedance: 600 Ohms
- Input Level: -10 dBm min.
- Music Source Impedance: 8-600 Ohms
- Music Source Level: -10 to -18 dBm
- Speaker Output Impedance: 8 Ohm (1 way)
- Output Level: -10 dBm (1 way)  
1 watt (Talkback)
- DC Power Output: -24 Vdc at 1.5 Amps
- Power Requirements: 115 Vac 2 Amps  
or  
230 Vac @ 1 Amp (Slo-blo)
- Tone Activation:
  - Clock Tone – Dry Contact
  - Night Ring Tone – Dry Contact or Ring Voltage  
-90 Vac (20-30 Hz)
- K5 and K6 Relay Contacts:
  - Rated 1 Amp @ 125 Vac
  - 2 Amp @ 30 Vdc

### **Access Methods**

- Electronic Key System (C. O. Line Position)
- PABX (Loop or Ground Start Trunk)
- 1A2 Key Systems (400 Type Line Card required)
- 600  $\Omega$  Page port equipped with contact closure and DTMF dialing capability
- Dedicated single line telephone

### **Additional Equipment Required**

- Backboard/mounting surface
- 25 pair cable with female connector on one end
- One 66 split block
- Speakers
- Cat 3 or Cat 5 twisted 2-pair cable (for speaker connections)

### **Physical Description**

The V-2006A-E and V-2006AHF-E are contained in single, gray steel cases which can be wall or shelf-mounted.

V-2006A-E:	10.90"H x 13.00"W x 2.70"D (27.69cm H x 33.02cm W x 6.86cm D) 6.2 lbs. (2.8 kg)
V-2006AHF-E:	10.90"H x 13.00"W x 2.70"D (27.69cm H x 33.02cm W x 6.86cm D) 7.5 lbs. (3.4 kg)

### **Environment**

Temperature:	32 to 104 Degrees F 0 to 40 Degrees C
Humidity:	0-85% non-precipitating

### **Features of the V-2006A-E**

- Time Clock & Night Ring Tones (single/warble)
- Override Input (trunk port access)
- Two Auxiliary Contact Closures
- Programmable per Zone
  - Background Music
  - Clock (single tone)
  - Night Ring (warble tone)
  - Group Calls
  - All Call
  - One-way/Talkback (V-2006AHF-E for Talkback)
- Three group calls and one all call group
- Volume Controls for:
  - Background Music (music mutes during page)
  - Clock and Night Ring Tones
  - All Call
- Switch Selectable
  - Dial Tone
  - Ringback Tone
  - Loop or Ground Start
- Battery Backup Input (for VPB-260 only)
- Inhibit Option for "Meet Me" Answer.
- Common all call link for up to (10) V-2006A-E/V-2006AHF-E units

### **Features of the V-2006AHF-E**

- 6 zones of handsfree talkback (one-way or mixed) paging (one handsfree output per zone).
- Two volume controls for handsfree paging Page (Phone to Speaker) Receive (Speaker to Phone)
- Tone options (Dip switch selectable on a system basis):
  - 1 - dial tone
  - 2 - alert tone (ringback tone)
  - 3 - repeated alert tone

## **SYSTEM OPERATION**

### **DO NOT OPERATE UNIT WITH COVER REMOVED!**

- **To Access Paging/Override:** Press CO line key, dial trunk access code or access page port if applicable
- **System Dial Tone:** If so optioned (dip switch #1), the V-2006A-E/V-2006AHF-E returns dial tone
- **Dialing Zones:** Dial 1 to 6 for individual zones
- **Dialing All Call:** Dial 0 for All Call
- **Dialing Groups:** For Groups 1, 2, or 3 – dial 7, 8, or 9 respectively
- **Activating Make or Break Contact Closures;**
  - K5:** After dialing any individual zone, press the asterisk (\*) once for 2.2 seconds of relay closure
  - K6:** This closure activates as long as zone 6 is active
- **Dialing Another Zone:** Press pound (#) key to return dial tone
- **Priority Sequence**
  - 1) Time Clock Tone
  - 2) Override Page
  - 3) All Call Link
  - 4) Page
  - 5) Warble Tone
  - 6) Background Music

### **Background Music**

Background music may be connected to control unit. Background music will mute in zone paged if the zone is programmed for background music.

### **Page Override**

Requires use of a second vacant C. O. line position or vacant loop or ground start trunk port for access.

**OPERATION:** Press line key (electronic key system) or dial trunk access code (PABX) for override access (override busy tone will be heard). Dial the zone and make announcement. The unit will disconnect when you hang up, re-establishing the overridden page.

**Inhibit Option (Meet Me Answer)**

The V-2006A-E/V-2006AHF-E is equipped with an inhibit feature that automatically mutes output to the speakers and allows a handset conversation between the paging party and a single line telephone connected to the paging Tip and Ring. A single line telephone modified for "A" Lead Control and a 5.1K ohm 1/4 watt resistor is required to use the inhibit function.

**NOTE:** If the inhibit option has been connected to a single line phone and that phone goes off hook during a page, the speakers will mute.

Inhibit does not affect the override feature.

**Warble and Single Tones**

Warble tone is activated when a common audible contact closure or 90 Vac ring voltage is supplied by the telephone system to UNA closure or UNA ring input. A single tone may be activated by an additional contact closure to the clock tone input.

**Group Call**

Each group can be programmed with any combination of zones. Zone may be included in multiple groups. Dial codes for group call are 7, 8, and 9. Group calls are one-way only.

**All Call Group**

Each zone, 1 through 6, can be programmed for all call (group 0). When "0" is dialed, all zones activate including group 0 of any expansion unit.

**Page Port Access**

Page Port requires a 600 Ohm page port ***that will pass DTMF for zone selection and is equipped with a separate "page enable" contact closure.***

Additionally, the page port must be capable of passing bi-directional audio if talkback is used.

**Expansion Unit**

Up to ten V-2006A-E/V-2006AHF-E units can be connected together to provide a system wide all call. Modular RJ11 plugs J7 and J9 are provided for this expansion setup.

**INSTALLATION**

**NOTE:** *The telephone system referred to in this document is the customer premise equipment such as a key system or PABX. The V-2006A-E/V-2006AHF-E CANNOT be connected directly to the public telephone network (a central office line). All connections must be made prior to plugging the unit to AC power.*

**Mounting**

The V-2006A-E/V-2006AHF-E was designed for wall or table mounting. Secure unit to wall studs or suitable brace away from heat sources or strong magnetic fields (motors, fans, power supplies, etc.) with control and terminal strip accessible. Four wood screws are included for mounting.

**NOTE:** All controls and terminations are accessed by removing the small right side panel. To remove panel, loosen the two screws holding the panel in place and lift panel away from the board.

**SWITCH SELECTABLE OPTIONS**

Refer to Figure 2.

**Loop/Ground Start Access**

If the V-2006A-E/V-2006AHF-E is being used with Loop/Ground Start Access, set SW6 to ON (Up). SW2 selects loop or ground start access from the telephone system. SW1 selects loop or ground start access for the override feature.

**NOTE:** *When using a ground start trunk port, a ground strap must be used to connect GND of the V-2006A-E or V-2006AHF-E to an appropriate telephone system ground (See Figure 1).*

**Page Port Access**

If the V-2006A-E/V-2006AHF-E is being used with a page port, set SW6 Battery Feed to OFF (Down Position).

Page port must:

1. provide dry page enable contact closure
2. pass DTMF tones for zone selection
3. pass audio in both directions when used with V-2006AHF-E for handsfree talkback

**Dial Tone, Alert Tone/Ringback Tone**

There are four (4) dip switches for setting options also located on the board (See Figure 2 also).

SW3 Dip Switch Options	OFF (Up) (Away from Board)	ON (Down) (Toward Board)
4	Not Used	Not Used
3*	Repeated Alert Tone	No Repeated Alert Tone
2*	Alert Tone/ Ringback Tone	No Alert Tone
1	Dial Tone	No Dial Tone

**NOTE:** \* Alert Tone and Repeated Alert Tone are available only on V-2006AHF-E handsfree outputs.

### **Telephone System Access Connections**

A 66 block with 50-pin female amphenol connector is required. See Figure 1 for 66 block pinouts. Tip and ring connections can be made to the RJ11 (J4) with a modular cord or punched down on the W/BL pair on the block.

### **Page Port Connections**

Make certain Battery Feed switch is OFF. SW6 should be in the Down Position. Connect Tip, Ring of Page Port to W/BL, BL/W. Connect wiring from telephone system dry contact closure to W/BR and O/W of the 66 block.

### **Connection of One-Way Amplified Speakers**

See Figure 1, 66 Block Connections.

**NOTE:** The V-2006A-E/V-2006AHF-E provides external power of 30 power units (1.5 amps of 24 Vdc) to operate amplified speaker assemblies. Additional power supplies are required for speakers using power over the 30 power units. When using additional power supplies, make certain:

- 1) The -24Vdc outputs are not connected to each other;
- 2) Each speaker is connected to only one power source (talkback speakers do not require power);
- 3) All power supply grounds are connected to copper cold water pipe earth ground. The use of an electrical ground in place of a direct cold water pipe ground may introduce noise into the paging system.

### **Power Connections**

The V-2006A-E/V-2006AHF-E is provided with a NEMA 5-15 cordset.

### **V-2006A-E Volume Adjustments**

There are three volume controls on the unit for individual adjustment of:

- Background Music
- Tones
- All Call

Clockwise adjustment increases volume, counterclockwise decreases volume. ***During initial set up, adjust individual speaker volume controls to page level first, then adjust volume on page unit to the desired level for music and tones.***

### **V-2006AHF-E Volume Adjustments**

There are six volume controls on the V-2006AHF-E to control the volume of the handsfree talkback outputs. They are:

- Phone to Speaker (adjusts volume of a page from phone)
- Speaker to Phone (adjusts response volume from speaker; should be turned as low as possible)
- Page (adjusts volume Group Call on handsfree outputs)
- All Call
- Background Music
- Tones

Refer to Figure 2 for location of the volume controls.

### **Connections for the V-2006AHF-E**

The V-2006AHF-E is programmable on a per zone basis for one-way or talkback communication. A single talkback zone may have both one-way and talkback speakers. One-way amplified speakers may be connected to the handsfree output of a zone programmed for talkback to augment the page output on that zone.

***NOTE: Only talkback speakers are able to receive reply. No more than two (2) 45-Ohm talkback speakers should be connected to any talkback zone. Do not use 8-Ohm speakers.***

### **Connection of Talkback Speakers (V-2006AHF-E only)**

See Figure 1, 66 Block Connections.

## OPTIONAL CONNECTIONS

### Background Music Connections

Connect the low level (-10 to +18 dBm, 8-600 Ohm) output of music source to the (W/G) and (G/W) terminals of the cross connect block. Adjust music volume (page overrides music).

**NOTE:** Failure to use a low level music source could cause music crosstalk on zones not receiving music and may override the mute of music during page.

### Time Clock Closure (Single Tone) Connections

Time clock contact closure connects to - V/G, G/V. Time clock signaling will override page.

### UNA Closure Connections

Telephone System Night Answer contact closure connects to - V/BR, BR/V. This tone will override music but is overridden by a page.

### UNA Ringing Connections

90V Night Answer Ring connects to - V/S, S/V. Telephone system standard ring voltage from these connections will activate a night ring tone. This tone will override music but is overridden by page.

### Override Connections

Page override can be activated by a vacant C. O. line position, loop start or ground start trunk or dedicated single line phone. Connect telephone system override via a telephone modular cord to override RJ11 jack (J5) or Tip, Ring to the W/O, O/W terminals of the cross connect 66 block.

### Remote Door Unlock with Tone Dial Telephone – K5 Relay (See Figure 2)

Before connecting an electric strikeplate to the V-2006A-E/V-2006AHF-E, consult the manufacturer's instruction for the proper installation arrangement. The dry contact closure is operated by pressing the asterisk (\*) key on a tone dial telephone after a zone has been accessed. The contact is rated at 1A @ 125Vac or 2A @ 30Vdc.

### Zone 6 Auxiliary – K6 Relay

The V-2006A-E/V-2006AHF-E contains an auxiliary set of make/break contacts which can be used to operate mute contacts on a high powered amplifier or other peripheral devices. Zone 6 dry contact closure operates when Zone 6 is activated alone or in together with a group call or all call. The contacts are rated at 1A @ 125 Vac or 2A @ 30 Vdc.

## PRECAUTIONARY DESIGNATIONS

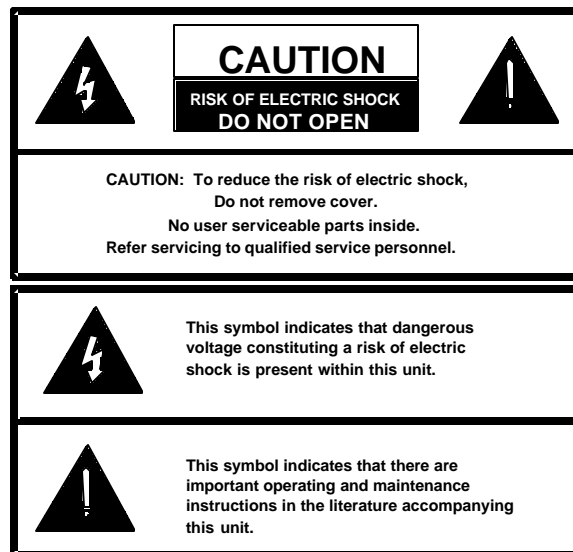

- Connect cordset to unit via IEC 320 female connector located on one end of cordset to IEC 320 male appliance coupler located on the V-2006A-E.
- **For 115 Vac** use, verify fuse rating of 2 amps and voltage selector switch displays 115 Vac.
- **For 230 Vac** use, verify the fuse rating of 1 amp and voltage selector switch displays 230 Vac.
- After all required connections have been made, plug the cordset into appropriate AC wall outlet.

## TECHNICAL ASSISTANCE

Assistance in troubleshooting is available from the factory. When calling, you should have a multimeter, several clip leads, a spare telephone test set available and be calling from the job site.

Call (540) 563-2000 and ask for Technical Support, or call (540) 767-1555 for Valcom 24-hour Automated Support or visit our website at <http://www.valcom.com>.

Should repairs be necessary, contact your local distributor for instructions.

## PROGRAMMING FEATURE CHART

LED	FEATURES	ZONES					
		1	2	3	4	5	6
D1	Handsfree (with V-2006AHF-E only)						
D2	Background Music						
D3	Night Ring						
D4	Clock Tones						
D5	Included in Group #1						
D6	Included in Group #2						
D7	Included in Group #3						
D8	Included in All Call						

PROGRAM EXAMPLE*
6
0
1
1
1
0
0
0
1

To Program Each Zone  
**Press: #**  
 Dial: Zone Number  
 Enter: "1" to Enable  
 Or  
 "0" to Disable  
 For each of the 8 features

### PROGRAM EXAMPLE:

Zone 6 Programmed for One-Way Paana. Background Music. Night Ring. Clock Tones. Not in Group 1-2 or 3. and All Call.

## PROGRAMMING INSTRUCTIONS

System programming is non-volatile and is not affected by power outages.

1. Complete Programming Feature Chart.
2. Connect a single line tone dial phone or butt set to the RJ11 jack J6 (Program Jack).
3. Go OFF HOOK, All LEDs illuminate for 1 second and then extinguish. Program tone will be heard.
4. Press # key (program tone breaks).
5. Dial the number of the zone to be programmed. Program ready tone (3 short bursts will be heard and the first LED will flash).
6. Enter "1" to Enable or "0" to Disable each of 8 features listed in chart above. As each entry is made, the next LED will begin flashing.

## PROGRAM TESTING INSTRUCTIONS

1. Connect a single line tone dial phone or butt set to the RJ11 jack J6 (Program Jack).
2. Go OFF HOOK, All LEDs illuminate for 1 second and then extinguish. Program tone will be heard.
3. Press \* key (program tone breaks). Dial the number of the zone to be checked.
4. Illuminated LEDs represent enabled features.
5. LEDs extinguish after 5 seconds and program tone returns.
6. Repeat the procedure for each zone.

### NOTES:

1. If the telephone is unplugged from the program jack while programming a zone, the existing program for that zone will not be affected.
2. The control unit cannot be used for paging while a telephone is plugged into the program jack and receiving the "PROGRAM TONE."
3. If numbers other than 1-6 are dialed after dialing "#" or "\*", a re-order tone will be heard. Programming must be initiated again, starting with going off hook.
4. If numbers other than "1" or "0" are dialed after dialing "#" and a valid zone number, the re-order tone will be heard. Programming must be started over beginning with going off hook.
5. **Tone Definitions:**
  - Program Tone/Dial Tone-Continuous Tone - (200 Hz, square wave).
  - Program Ready Tone/Override Busy Tone - Three short bursts of tone; 1/4 second on, 1/4 second off (400 Hz, square wave).
  - Re-Order Tone - Interrupted tone; 1/2 second on, 1/2 second off (400 Hz, square wave).

## TROUBLESHOOTING CHART

<b>SYMPTOMS</b>	<b>PROBABLE CAUSES AND SOLUTIONS</b>
Cannot Access Paging	<p>A) Check V-2006A-E switch settings. Verify that the phone system connections and programming are consistent with V-2006A-E switch settings. (Page Port, C.O. Port).</p> <p>B) Remove V-2006A-E Tip and Ring connections from telephone system. Set switches 1 &amp; 2 for Loop Start (Down). Set switch 6 for C. O. Port Access (Up). Access paging with a telephone test set in talk position across the V-2006A-E tip/ring input (W/BL pair).</p>
Cannot Access Zone from Page Port	<p>A) Monitor access port with a telephone test set in monitor position across the phone system paging output. Verify port is passing DTMF.</p> <p>B) Monitor paging zone output on V-2006A-E block with telephone test set. <u>Verify audio present when paging.</u></p>
No Speaker Output	<p>A) Check AC power source and AC line fuse on V-2006A-E (Disconnect power before removing fuse).</p> <p>B) Connect tone generator (cable tracer) to zone output audio pair on V-2006A-E block. <u>Verify tone plays over speakers or horns.</u></p>
No Background Music	<p>A) Adjust music volume control (Adjustment POT R6).</p> <p>B) Monitor V-2006A-E background music input with telephone test set. Verify music is present.</p> <p>C) Check programming. Verify zone is programmed for background music.</p> <p>D) Check switch settings. Verify access method from phone system matches V-2006A-E switch settings (Page Port, C. O. Port ...).</p>
Programmed Feature Not Working	<p>A) Check V-2006A-E programming for that option. Re-program zone as necessary.</p>

### VALCOM U.K. WARRANTY

This product, bearing the "VALCOM" Trademark, excluding the batteries, is guaranteed by the manufacturer for the period of one year from the date of purchase and will, during this period, be repaired or replaced (with the same or a similar model), at our option, free of charges, if there is any defect due to faulty materials or workmanship. This guarantee does not cover defects arising from accidental damage, misuse or wear and tear, and is available only to the original purchaser of the product from an official "VALCOM" distributor or dealer.

This guarantee applies to all Valcom products purchased and used in the EEC. Products should be returned to your nearest Valcom distributor or dealer. If, however, the product has not been purchased in the EEC country where the distributor or dealer is located, the customer may be advised to return to the EEC country where the purchased originated, if parts are unavailable, or there are other unavoidable circumstances which hinder, or prevent service being given under guarantee.

Any person claiming under this guarantee must, on returning the product, supply proof of the date of purchase and a brief description of the nature of the fault.

NOTE: PROOF OF PURCHASE WILL BE ACCEPTED IN THE FORM OF EITHER THE ORIGINAL RECEIPT OF PURCHASE OR THE GUARANTEE CERTIFICATE AND SUCH RECEIPT OR CERTIFICATE MUST BEAR THE DISTRIBUTOR OR DEALERS OFFICIAL STAMP AND THE DATE OF PURCHASE.

Charges will be made for all repairs unless either the purchase receipt or the stamped and dated Guarantee Certificate is returned with the product.

The guarantee does not effect the Statutory Rights of the customer.

**FIGURE 1**

**66 BLOCK CONNECTIONS FOR THE V-2006A-E AND V-2006AHF-E**

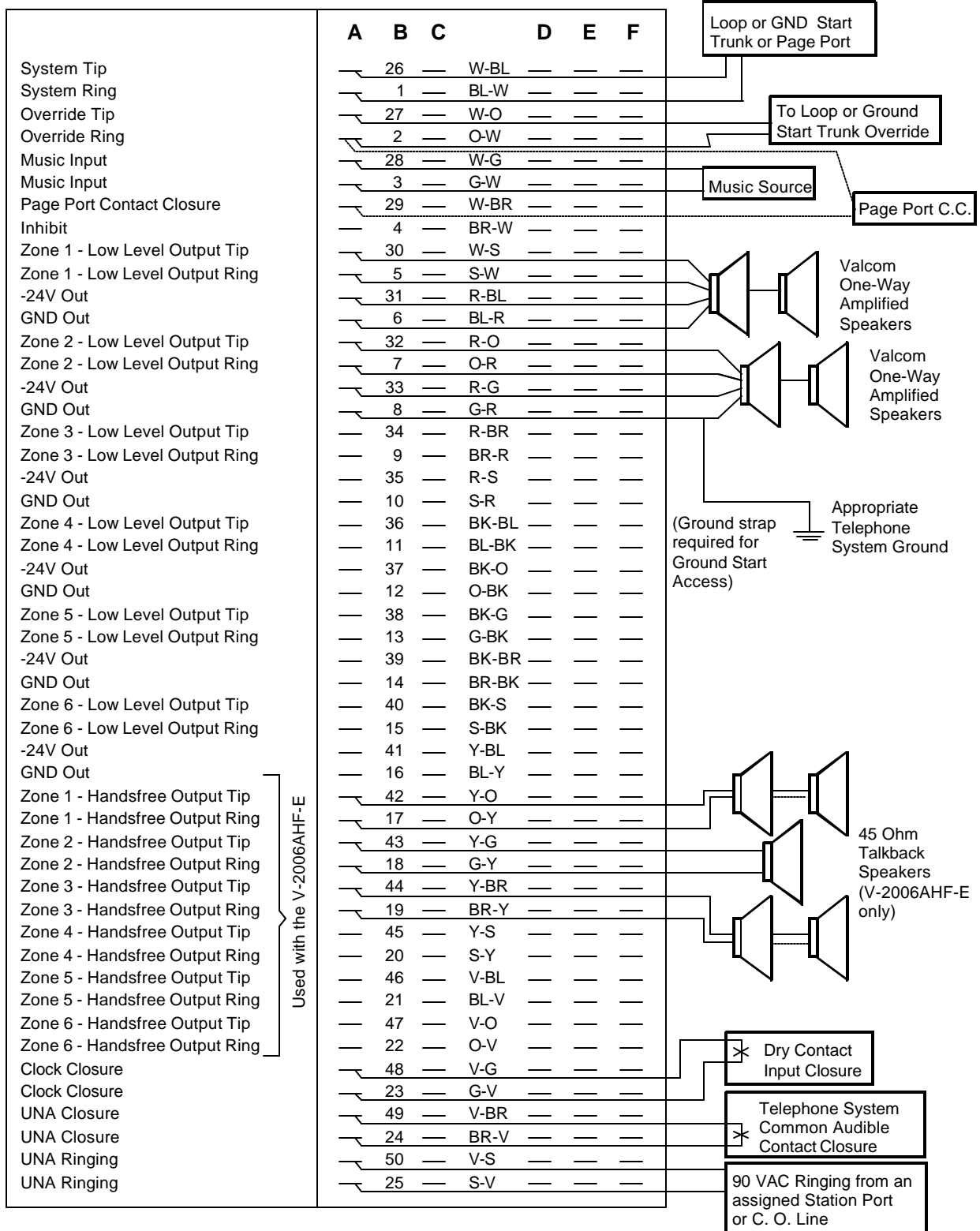



**FIGURE 2**  
**V-2006A-E/V-2006AHF-E**

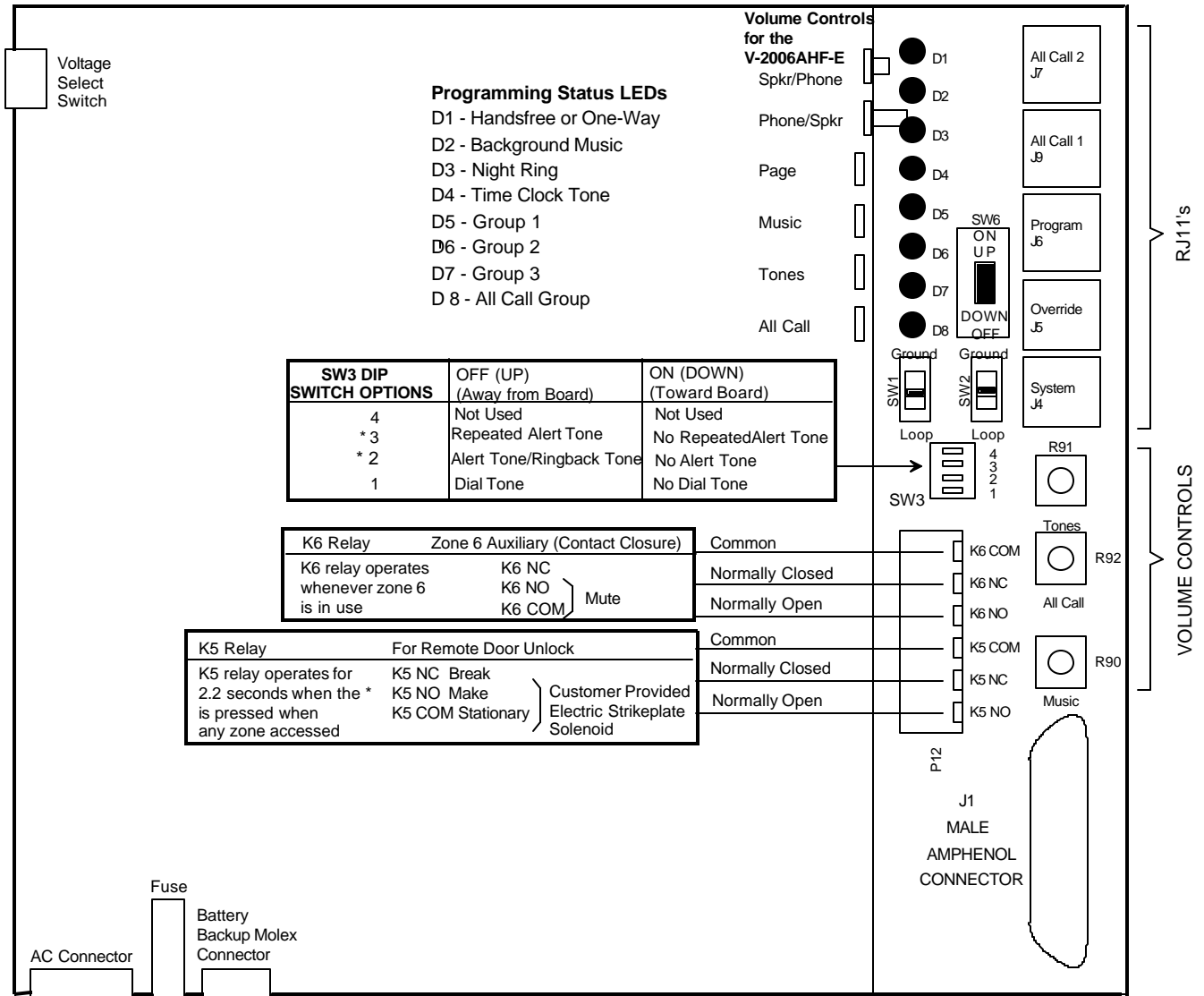

This side of the V-2006A-E/V-2006AHF-E oriented toward floor.

Slide Switches

- SW1 - Ground Start or Loop Start Trunk for Override Feature
- SW2 - Ground Start or Loop Start Trunk Access
- SW6 - Battery Feed (ON/OFF)

Switch	SW1	SW2	SW6
Loop Start Trunk C.O.	Down	Down	Up
Ground Start Trunk	Up	Up	Up
Page Port	---	---	Down