

VIP-9890AL-CB Vandal Resistant IP Talkback Call Station

INTRODUCTION

The VIP-9890AL-CB IP Talkback Call Station allows communication to Valcom FXO or FXS units and SIP-enabled telephone systems via an IP network. The VIP-9890AL-CB combines a rugged; weather-resistant talkback paging horn with a vandal-resistant enclosure, which is ideally suited for high-noise, exposed environments.



SPECIFICATIONS

Access Methods

- PBX, FXO Port via Valcom FXS Network Station Port
- POTS telephone set via Valcom FXS Network Station Port
- PBX, FXS Port via Valcom FXO Network Trunk Port
- Valcom Multicast Page Group
- SIP – enabled telephone system

Features

- RJ-45 for network connection
- 1 Form C relay output
- Network activity LEDs
- Power over Ethernet (PoE) 802.3af compatible
- Long Line Extender

Dimensions/Weight

Speaker Assembly / Backbox:

- 10.0" H x 12.5" W x 4" D (25.4cm H x 31.75cm W x 10.2cm D)
- Weight: 10.75lbs. (4.89 kg)

Network Interface

- 1.62" H x 5.63" W x 3.45" D (4.11 cm) x (14.30 cm) x (8.76 cm)
- **with brackets** – 8.22" W (20.87 cm)
- Weight: 2.10 lbs. (0.95 kg)

Nominal Specifications

Output Impedance: 45 Ohms
 Output Level: 100 dB@ 4' on axis
 Relay Current: 1 AMP @ 24VDC

Nominal Power Requirements

Via 802.3af (PoE) Ethernet Switch Class 3

Environment

Network Interface

Temperature: 0 to +40° C
 Humidity: 0 to 85% non-precipitating

Intercom Unit:

Suitable for indoor or outdoor installation

Packing List

Qty	Item
1	VIP-9890AL-CB Call Station
1	Network Interface w/Mounting Brackets
1	VSP Document
4	Tamper Resistant Hardware
1	VIP172-RLY Relay Block
4	Wood Screws

Precautionary Designations

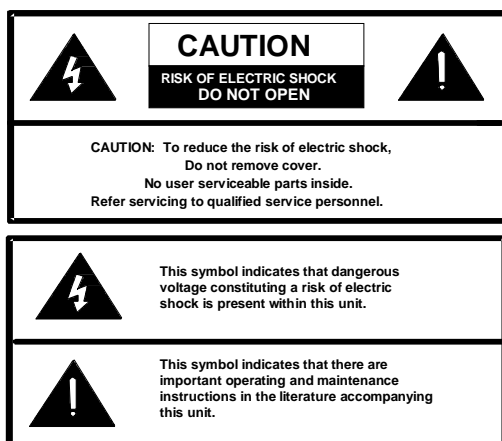

FCC Information

This equipment has been tested and found to comply with the limits for a Class A digital device, pursuant to Part 15 of the FCC Rules. These limits are designed to provide reasonable protection against harmful interference when the equipment is operated in a commercial environment. This equipment generates, uses and can radiate radio frequency energy and if not installed and used in accordance with the instruction manual, may cause harmful interference to radio communications. Operation of this equipment in a residential area may cause harmful interference in which case the user will be required to correct the interference at his own expense.

INSTALLATION

Operation:

The VIP-9890AL-CB provides talkback access via network connection to customer telephone system or stand alone telephone set. Interface to customer telephone system can be via SIP registration to a Voice over IP (VoIP) telephone system, FXO port (when used with a Valcom FXS Network Station Port), or FXS port (when used with a Valcom FXO Network Trunk Port). Pressing the call button on the speaker assembly initiates a call to a user-specified telephone number, and the call assurance LED behind the intercom unit face plate begins to flash. When the call is answered, a hands-free communications path is established to the speaker, and the call assurance LED behind the face plate remains lit. The form C relay included with the VIP-9890AL-CB may be activated by pressing the # key on the answering telephone, with the relay typically being used to activate door entry equipment.

Mounting

For enhanced protection against static electrical discharge, it is recommended the intercom unit shipped with the VIP-9890AL-CB be installed onto a grounded electrical box, if surface mounted, ground box to local ground.

The VIP-9890AL-CB speaker enclosure is designed for double gang FD electrical box mounting and must be within 350 feet of the VIP-9890AL-CB Network Interface.

The VIP-9890AL-CB Network Interface is designed for wall mounting and must be within 100 meters of the network switch. Using the screws provided, attach the mounting brackets to the Network Interface, then secure the Network Interface to the wall. Remove the speaker assembly from the packing container. Using a Phillips screwdriver, remove the two screws securing the front grille to the enclosure. Pre-drilled 13/64" mounting holes in the back of the enclosure are designed to fit a single gang, double gang or octagon outlet box. If not attaching to an outlet box, use the enclosure as a template. Hold the enclosure in the desired position on the wall and mark the location of mounting holes. Depending on wall construction type, prepare the mounting hole locations on the wall to securely attach the enclosure.

Wiring may be inserted through the large hole in the back of the enclosure, or through the knockout hole in the top of the enclosure. Insert wiring for signal connections and relay connections (if used) through desired hole. Use mounting hardware (not included) appropriate for the wall type to securely mount the enclosure to the wall.

After making signal connections, align the grille/speaker assembly with the enclosure. Install the four supplied tamper-resistant screws through the grille into the enclosure. Use a 1/8" security hex bit to tighten the screws securely.

Power Connections

The only method of powering a VIP-9890AL-CB Network Interface is via a Power over Ethernet (PoE) switch or power injector meeting the 802.3af specification.

Make all required signal connections before connecting to Ethernet switch or power injector meeting the 802.3af specification.

Network Connection

The VIP-9890AL-CB Network Interface has one RJ-45 NETWORK connector and one RJ-45 Signal Output connector.

Use a standard Ethernet patch cable to connect the NETWORK connector of the VIP-9890AL-CB Network Interface to an Ethernet switch.

Signal Connections

Use standard Category 5 UTP cable to connect the VIP-9890AL-CB Network Interface to the Intercom unit. Connect the RJ-45 jack (labeled Signal Output) on the Network Interface to the RJ-45 jack on the back of the speaker assembly using a standard Ethernet patch cable. See Quick Start Installation, Figure A.

For longer distances between the network interface and the speaker (up to 350'), VM-186 adapters (not included), or other Standard Category 5 straight-through terminators, may be used to extend the signal line. Refer to Quick Start Installation, Figure B.

Door Relay Connections

Access to the form C relay is provided via a three pin screw terminal block on the VIP-9890AL-CB speaker. The common contact is the middle terminal. The Normally Open contact is on the side labeled NO, the Normally Closed contact is labeled NC.

For higher security, the included VIP172L-RLY connection block can be used. Please refer to the High Security Relay Quick Start Installation guide for installation details.

Status Indicator Lights

The 9890AL-CB Network Interface has 2 status indication lights on the Ethernet connector:

Green LED: (Link) Indicates Ethernet connection when illuminated.

Yellow LED: (Activity) Indicator flashes to indicate network activity.

Setup

Information specific to your application will need to be programmed into the VIP-9890AL-CB using a computer. The PC used for programming should be connected to the same subnet as the VIP-9890AL-CB.

Setup will be done using the IP Solutions Setup Tool. Download the latest version of the free IP Solutions Setup Tool from the Valcom web site at www.valcom.com/vipsetuptool.

TECHNICAL ASSISTANCE

Assistance in troubleshooting is available from the factory. Call (540) 563-2000 and press 1 for Technical Support or via email at support@valcom.com.

When requesting assistance, you should include all available information. Information and troubleshooting procedures are available on the Valcom website at www.valcom.com.

Valcom equipment is not field repairable. Valcom, Inc. maintains service facilities in Roanoke, VA. Should repairs be necessary, attach a tag to the unit clearly stating your company name, address, phone number, contact person and the nature of the problem. Send the unit to:

**Valcom, Inc.
Repair & Return Dept.
5614 Hollins Road
Roanoke, Va. 24019-5056**

Quick Start Installation

- Step 1. An optional relay output is provided for activating electric door controls, strike plates, gates, etc. A Normally Open (NO) and Normally Closed (NC) connection is available. Consult the door equipment manufacturer's documentation for connections to their device. The relay can be activated by pressing the # key on the answering telephone.
- Step 2. Connect the IP Speaker to the Network Interface. If the IP Speaker is close to the Network Interface, a standard Patch Cable may be used to connect between them (Figure A). For longer distances, the VM-186 RJ45 Junction Boxes can be used to extend up to 350' between the IP Speaker and Network Interface (Figure B).
- Step 3. Connect the RJ45 cable from the network. This device is powered via Power over Ethernet (PoE). If PoE is unavailable from the network switch then an inline power injector will be required.
- Step 4. Program the IP Speaker using the VIP-102B IP Solutions Setup Tool.

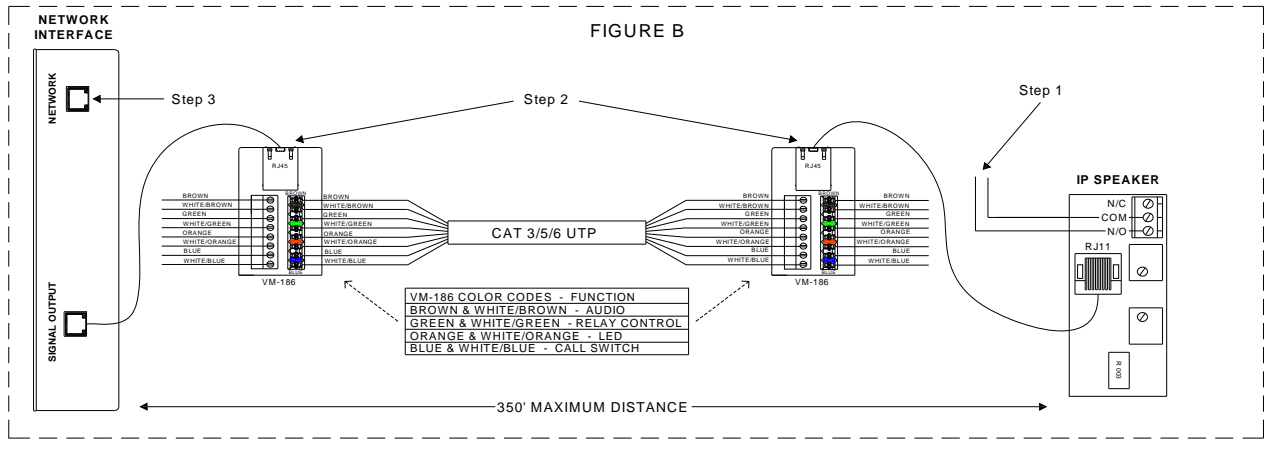
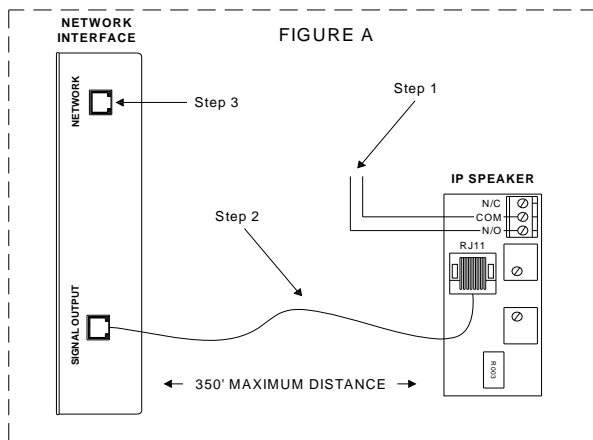

VALCOM LIMITED WARRANTY

Valcom, Inc. warrants its products only to the original purchaser, for its own use, to be free from defects in materials and workmanship under conditions of normal use and service for a period of one year from the date of shipment. This Limited Warranty obligation shall be limited to the replacement, repair or refund of any such defective device within the warranty period, provided that:

1. inspection by Valcom, Inc. indicates the validity of the claim;
2. the defect is not the result of damage, misuse or negligence after the original shipment;
3. the product has not been altered in any way or repaired by others and that factory sealed units are unopened (a service charge plus parts and labor will be applied to units defaced or physically damaged);
4. freight charges for the return of products to Valcom are prepaid;
5. all units 'out of warranty' are subject to a service charge. The service charge will cover minor repairs (major repairs will be subject to additional charges for parts and labor).

This Limited Warranty is in lieu of and excludes all other warranties, expressed or implied and in no event shall Valcom, Inc. be liable for any anticipated profits, consequential damages, loss of time or other losses incurred by the buyer in connection with the purchase, operation, maintenance, installation, removal or use of the product. The maximum liability of Valcom under this warranty is limited to the purchase price of the specific Product covered by the warranty.

Disclaimer. Except for the Limited Warranty provided herein, the product is provided "as-is" without any warranty of any kind whatsoever including, without limitation, any **WARRANTY OF MERCHANTABILITY, FITNESS FOR A PARTICULAR PURPOSE OR NON-INFRINGEMENT.**

This warranty specifically excludes damage incurred in shipment. In the event a product is received in damaged condition, the carrier should be notified immediately. Claims for such damage should be filed with the carrier involved in accordance with the F.O.B. point.

Headquarters:

Valcom, Inc.

5614 Hollins Road Roanoke, VA 24019-5056

Phone: (540) 563-2000 FAX: (540) 362-9800

High Security Relay Quick Start Installation Guide

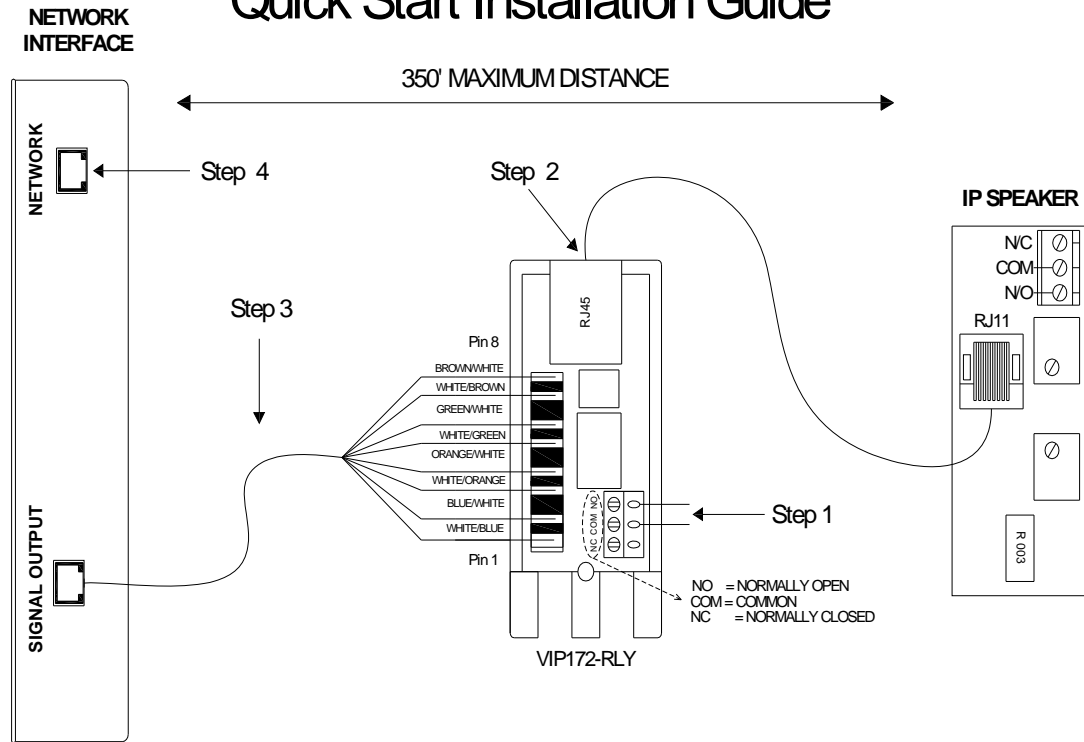

Step 1. An optional relay output is provided for activating electric door controls, strike plates, gates, etc. A Normally Open (NO) and Normally Closed (NC) connection is available. Consult the door equipment manufacturer's documentation for connections to their device. The relay can be activated by pressing the # key on the answering telephone.

Step 2. Connect the IP Speaker to the VIP172-RLY with standard CAT5 T568A or T568B straight-through cabling.

Step 3. Connect the punchdown block on the IP Speaker to the SIGNAL OUTPUT on the Network Interface with standard CAT5 cabling. RJ-45 connector at Network Interface should be wired using T568B standard.

Step 4. Connect the RJ45 cable from the network. This device is powered via Power over Ethernet (PoE). If PoE is unavailable from the network switch then an inline power injector will be required.

Step 5. Program the IP Speaker using the VIP-102B IP Solutions Setup Tool.

The VIP172-RLY External Relay adapter increases security for door unlock mechanisms. By installing the VIP172-RLY in a protected area, the relay connections can be protected from tampering. When installed inline as shown in this drawing, the relay connections on the Door Plate are not functional.