

VIP-160 TALKBACK IP CEILING SPEAKER

INTRODUCTION

The VIP-160 Talkback IP Ceiling Speaker enables handsfree talkback access to a single location over an IP-based LAN/WAN. This allows handsfree communication anywhere on the network. The VIP-160 levels are adjusted electrically via software during setup. A call switch input is provided for call in initiation. Power is provided to the VIP-160 via a Power over Ethernet (PoE) switch meeting the 802.3af specification.



SPECIFICATIONS

Access Methods

- PBX, FXO Port w/VIP-811
- POTS telephone set w/VIP-811
- PBX, FXS Port w/VIP-821
- Valcom M Cast Page Group
- SIP – enabled telephone system

Features

- RJ-45 network connection
- 802.3af compliant
- High Efficiency Class-D Amplifier

INSTALLATION

FCC Information

This equipment has been tested and found to comply with the limits for a Class A digital device, pursuant to Part 15 of the FCC Rules. These limits are designed to provide reasonable protection against harmful interference when the equipment is operated in a commercial environment. This equipment generates, uses and can radiate radio frequency energy and if not installed and used in accordance with the instruction manual, may cause harmful interference to radio communications. Operation of this equipment in a residential area may cause harmful interference in which case the user will be required to correct the interference at his own expense.

Packing List

Qty.	Item
1	VIP-160
1	VSP Document

DIMENSIONS/WEIGHT

- 13.00" Dia x 3.00" D
(33.02cm Dia. x 7.62cm D)
- Weight: 2.5 lbs (1.13 kg)

Environment

Temperature: 0 to +40° C
Humidity: 0 to 85% non-precipitating

Precautionary Designations

	CAUTION RISK OF ELECTRIC SHOCK DO NOT OPEN	
<p>CAUTION: To reduce the risk of electric shock, Do not remove cover. No user serviceable parts inside. Refer servicing to qualified service personnel.</p>		
	<p>This symbol indicates that dangerous voltage constituting a risk of electric shock is present within this unit.</p>	
	<p>This symbol indicates that there are important operating and maintenance instructions in the literature accompanying this unit.</p>	

Network Connection

The VIP-160 has one RJ-45 network connector on the rear panel. Connect the VIP-160 to an Ethernet switch. (See Figure 1).

Call Switch Connection

The Talkback IP Speaker provides a call switch input via screw terminal connections. See Figure 1 for detailed connections.

Mute Out Connection: The Mute Out may optionally be connected to the mute input of

Valcom Classroom audio management systems in order to suspend locally originated classroom audio during intercom announcements.

LED (+) and (-) Connection: LED (+) and (-) is a current limited output designed to illuminate an optional LED. The LED is intended to provide visual indication of call progress. The LED illumination will flash when the call switch is pressed and will continue to flash until the call is answered. The LED illumination will be solid while a connection to the IP Talkback Speaker is established.

-10 dB Line Level Out Connection: the -10dBm Line Level Out may be connected to up to 40 Valcom Self Amplified Speakers in order to provide additional sound reinforcement in an area.

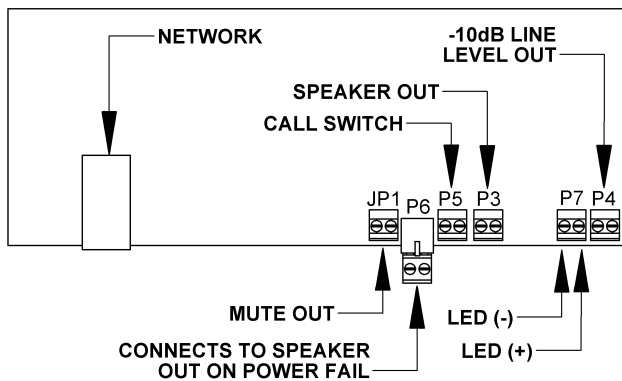

Figure 1. VIP-160 Connections

Setup

Information specific to your application will need to be programmed into the VIP-160 using a computer. The PC used for programming should be connected to the same subnet as the VIP-160. Setup will be done using the IP Solutions Setup Tool. Download the latest version of the free IP Solutions Setup Tool from Valcom web site at www.valcom.com/vipsetuptool.

MOUNTING

Cut an 8.50" diameter in ceiling tile. After connections have been made to the speaker, attach speaker to ceiling tile using the mounting hardware provided. (A metal backbox with rails is available separately as model V-9816M).

TECHNICAL ASSISTANCE

When trouble is reported, verify power is being supplied to the unit and there are no broken connections. If a spare unit is available, substitute a spare unit for the suspected defective unit.

Assistance in troubleshooting is available from the factory. Call (540) 563-2000 and press 1 for Technical Support or via email at support@valcom.com

When requesting assistance, you should include all available information. It is strongly suggested that you go to the web site and review the information at www.valcom.com.

Valcom equipment is not field repairable. Valcom, Inc. maintains service facilities in Roanoke, VA. Should repairs be necessary, attach a tag to the unit clearly stating your company name, address, phone number, contact person and the nature of the problem. Send the unit to:

Valcom, Inc.
Repair & Return Dept.
5614 Hollins Road
Roanoke, Va. 24019-5056

VALCOM LIMITED WARRANTY

Valcom, Inc. warrants its products only to the original purchaser, for its own use, to be free from defects in materials and workmanship under conditions of normal use and service for a period of one year from the date of shipment. This Limited Warranty obligation shall be limited to the replacement, repair or refund of any such defective device within the warranty period, provided that:

1. inspection by Valcom, Inc. indicates the validity of the claim;
2. the defect is not the result of damage, misuse or negligence after the original shipment;
3. the product has not been altered in any way or repaired by others and that factory sealed units are unopened (a service charge plus parts and labor will be applied to units defaced or physically damaged);
4. freight charges for the return of products to Valcom are prepaid;
5. all units 'out of warranty' are subject to a service charge. The service charge will cover minor repairs (major repairs will be subject to additional charges for parts and labor).

This Limited Warranty is in lieu of and excludes all other warranties, expressed or implied and in no event shall Valcom, Inc. be liable for any anticipated profits, consequential damages, loss of time or other losses incurred by the buyer in connection with the purchase, operation, maintenance, installation, removal or use of the product. The maximum liability of Valcom under this warranty is limited to the purchase price of the specific Product covered by the warranty.

Disclaimer. Except for the Limited Warranty provided herein, the product is provided "as-is" without any warranty of any kind whatsoever including, without limitation, any **WARRANTY OF MERCHANTABILITY, FITNESS FOR A PARTICULAR PURPOSE OR NON-INFRINGEMENT.**

This warranty specifically excludes damage incurred in shipment. In the event a product is received in damaged condition, the carrier should be notified immediately. Claims for such damage should be filed with the carrier involved in accordance with the F.O.B. point.

Headquarters:

Valcom, Inc.

5614 Hollins Road Roanoke, VA 24019-5056

Phone: (540) 563-2000 FAX: (540) 362-9800