

VIP-824A QUAD ENHANCED NETWORKED TRUNK PORT

INTRODUCTION

The VIP-824A Quad Enhanced Networked Trunk Port allows most loop start station ports to be connected to a managed IP-based LAN/WAN. SIP connectivity allows the VIP-824A to act as a gateway device between a SIP telephone system and the other Valcom paging systems, such as the MultiPath.



SPECIFICATIONS

Access Methods

- PBX, FXS Port
- SIP

Features

- RJ-45 for network connection
- 4 RJ-11 FXO connections
- 4 RJ-11 failover telephone connections
- Decode Caller ID signals
- Front panel activity LED
- Network activity LEDs
- 2.5mm jack for DC power
- Power over Ethernet (PoE) 802.3af compatible

Dimensions/Weight

- 1.38 H x 6.13" W x 5.25" D
(3.50cm H x 15.6cm W x 13.33cm D)
- Weight: 1.25 lbs. (0.57 kg)

Nominal Specifications

Input Impedance:	600 Ohms
Input Level:	-10dBm
Output Impedance:	600 Ohms
Output Level:	- 10dBm nominal

Nominal Power Requirements

Via back panel barrel connector:

Voltage:	24VDC
Current:	325mA

Via 802.3af PoE Ethernet Switch:

802.3af:	Class 3
----------	---------

Environment

Temperature:	0 to +40° C
Humidity:	0 to 85% non-precipitating

INSTALLATION

NOTE: The telephone system referred to in this manual is the customer premise equipment such as an electronic key system, a PBX or a dedicated single line telephone sets. The VIP-824A is not intended for direct or indirect connection to the public telephone network. When used with a customer premise telephone system such as a key system or PBX system, these units are interfaced to the system via a fully protected system central office port, which is a fully protected interface device. Also, the host system must be configured to disallow central office trunk conferencing in order to prevent indirect connection to the public network.

Precautionary Designations

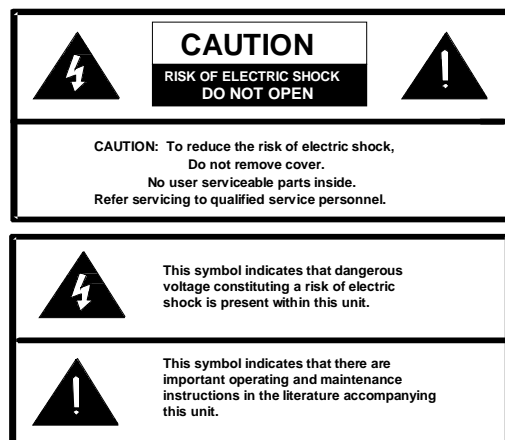

FCC Information

This equipment has been tested and found to comply with the limits for a Class A digital device, pursuant to Part 15 of the FCC Rules. These limits are designed to provide reasonable protection against harmful interference when the equipment is operated in a commercial environment. This equipment generates, uses and can radiate radio frequency energy and if not installed and used in accordance with the instruction manual, may cause harmful interference to radio communications. Operation of this equipment in a residential area may cause harmful interference in which case the user will be required to correct the interference at his own expense.

Mounting

The VIP-824A is designed for wall, table or rack mounting.

Table: Provided with the VIP-824A are four rubber pads. Peel pads from their carrier backing and place at the four corners of the bottom of the unit.

Wall: Using the template on last page of this document, mark the location of the bracket screw holes on the wall. Drill 5/64" pilot holes, 3/4" deep, at each screw location and use the wood screws provided to attach the brackets to the wall. For surfaces other than wood, use hardware appropriate for the surface (not included). With the brackets securely attached to the wall, attach the VIP-824A to the brackets using the included hardware. Figure 2 illustrates the bracket assembly.

Rack: Following the assembly drawing, attach the two mounting brackets to the VIP-824A unit. Using rack screws, mount the VIP-824A in an available 1U rack slot. See Figure 1.

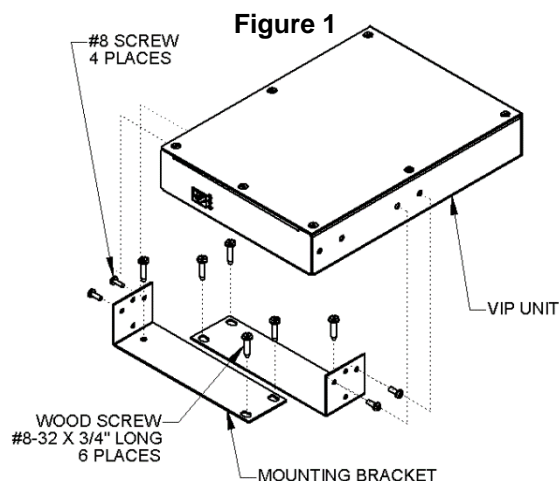
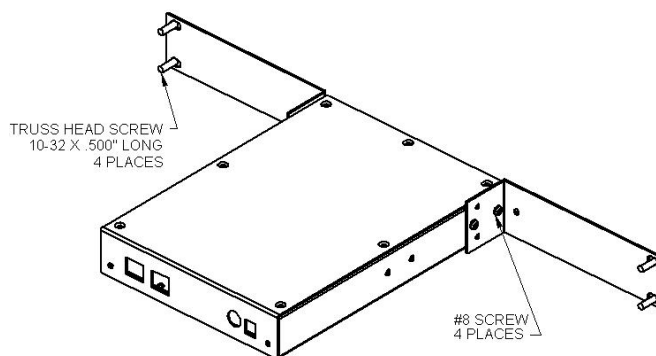

Power Connections

The preferred method of powering a VIP-824A is via a Power over Ethernet (PoE) switch meeting the 802.3af specification.

If the rear panel barrel connector is used for power, the preferred power supply is a Valcom VIP-324D.

Make all required signal connections before applying power to the unit. If powering via 802.3af, make sure all signal connections via the back panel are made then connect the VIP-824A to the Ethernet switch.

If power is supplied via the barrel connector, make sure all signal connections are secure. Attach the unit to the network via the front panel RJ-45 Ethernet connector. Apply power by plugging the power supply into the VIP-824A via the barrel connector on the rear of the VIP-824A.

Network Connection

The VIP-824A has one RJ-45 network connector on the front panel. Use a standard patch cable to connect the VIP-824A to an Ethernet switch. If the Ethernet switch is 802.3af compliant, the VIP-824A will draw power from it.

Signal Connections

Trunk Connections:

Connect a standard analog telephone to the VIP-824A via the rear panel RJ-11 jacks labeled Port 1 Line, Port 2 Line, Port 3 Line and Port 4 Line. Tip and Ring appear on pins 3 and 4 of this jack.

Failover Connection: RJ11 ports labeled “phone” are failover ports that become active during device power failure. During power failure, an analog telephone set connected to a “phone” RJ11 port will have access to equipment connected to the affiliated “line” RJ11 port. Tip and Ring appear on pins 3 and 4 of these ports.

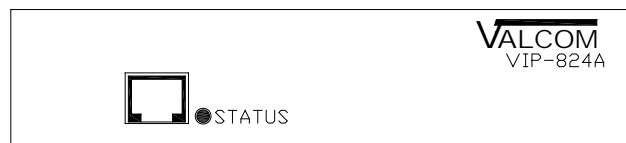

Front View

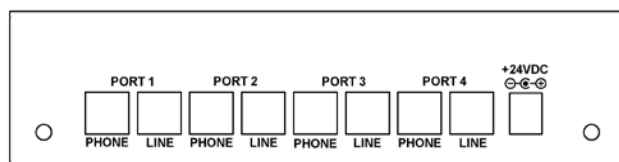

Rear View

Setup

Information specific to your application will need to be programmed into the VIP-824A using a computer. The PC used for programming should be connected to the same subnet as the VIP-824A. Setup will be done using the IP Solutions Setup Tool. Download the latest version of the free IP Solution Setup Tool from the Valcom web site at www.valcom.com/vipsetuptool.

Status Indicator Lights

The VIP-824A has 3 status indication lights on the front panel:

STATUS: Flashes during normal operation and solid during system startup.

Green LED: (Link) Indicates Ethernet connection when illuminated.

Yellow LED: (Activity) Indicator flashes to indicate network activity.

TECHNICAL ASSISTANCE

When trouble is reported, verify power is being supplied to the unit and there are no broken connections. If a spare unit is available, substitute a spare unit for the suspected defective unit.

Assistance in troubleshooting is available from the factory. Call (540) 563-2000 and press 1 for Technical Support or via email at support@valcom.com.

When requesting assistance, you should include all available information. General information and troubleshooting procedures are available on the Valcom web site at www.valcom.com.

Valcom equipment is not field repairable. Valcom, Inc. maintains service facilities in Roanoke, VA. Should repairs be necessary, attach a tag to the unit clearly stating your company name, address, phone number, contact person and the nature of the problem. Send the unit to:

Valcom, Inc.
Repair & Return Dept.
5614 Hollins Road
Roanoke, Va. 24019-5056

Warranty

Warranty information may be found on our website at www.valcom.com/warranty.

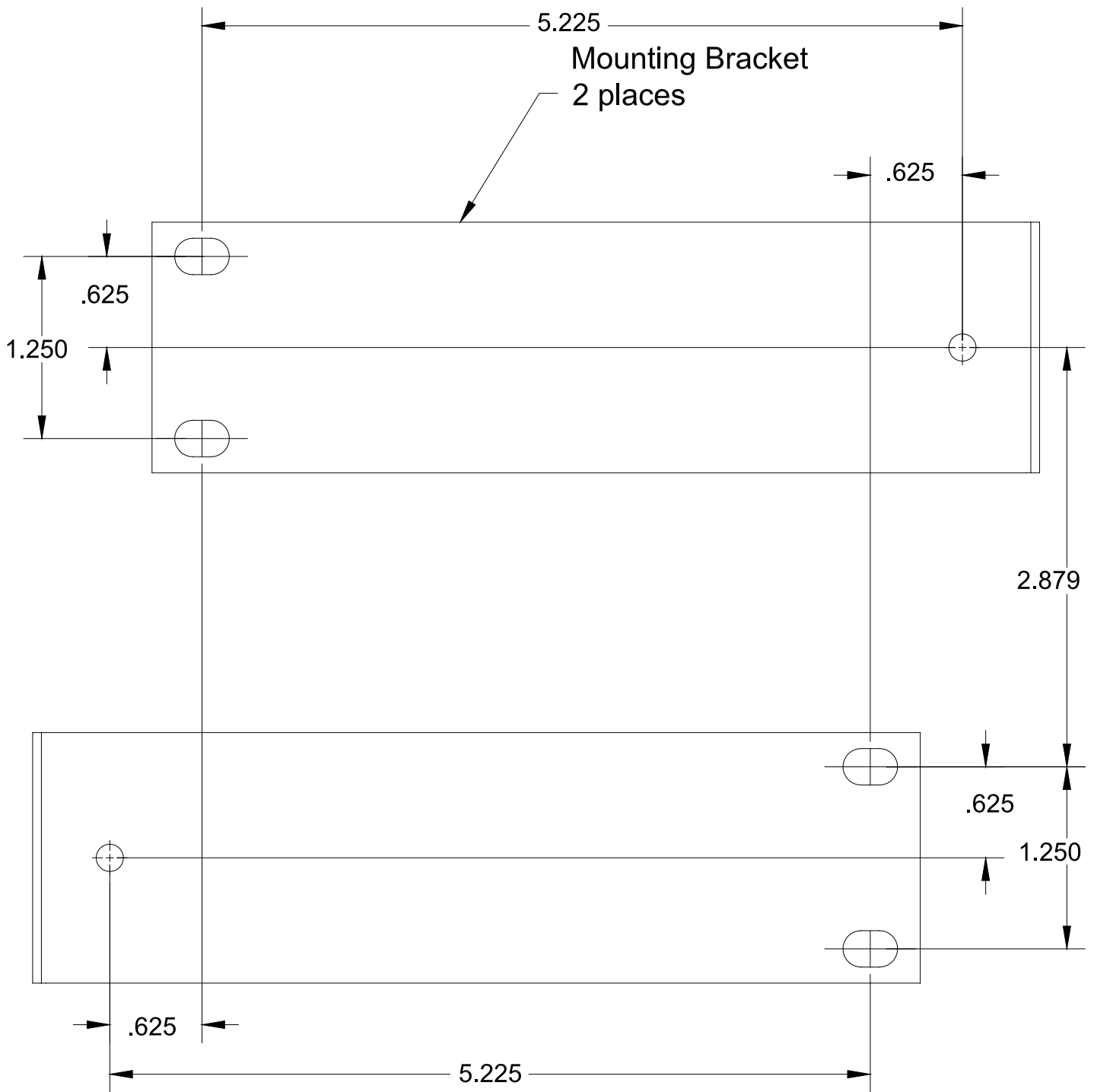

Place template in area where unit is to be mounted and mark. Install 2 mounting brackets to wall using 6 #8 wood screw x .750 long at center mark as shown. Check fit of unit between mounting brackets. When okay, install unit to the mounting brackets using 4 of #6-32 x 3/8 PHMS.

Mounting Unit to Wall Template