

V-2904

UNIVERSAL FOUR DOOR ANSWERING SYSTEM

INTRODUCTION

The V-2904, Universal Four Door Answering System, when used with Valcom Door Plate Speakers, provides voice paging with handsfree reply to up to four doors from any telephone location. The V-2904 initiates ring-in on the telephone system and sends a confirmation tone to the door speaker. The individual at the phone responding to the signal will determine if access should be allowed. Pressing a programmed code on the telephone dialpad or pressing the remote button will unlock the door to allow admission. The V-2904 also provides an alarm control output to alert an unauthorized entry.

These instructions contain the specifications and information necessary to install, operate and maintain the Universal Four Door Answering System.

FCC Notice

This equipment generates and uses radio frequency energy and if not installed and used properly, that is, in strict accordance with the instructions listed in this User's Manual, may cause interference to radio and television reception.

It has been tested and found to comply with the limits for a Class B Computing Device in accordance with the specifications in Subpart B of Part 15 of the FCC rules, which are designed to provide reasonable protection against such interference in a residential installation. If this equipment does cause interference to radio or television reception, which can be determined by turning off the equipment and seeing if the interference stops, the user is encouraged to try and correct the interference by one or more of the following measures:

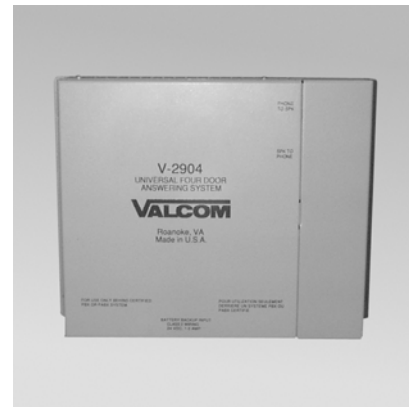

- Reorient the receiving antenna
- Relocate the equipment with respect to the radio or television
- Move the equipment further away from the radio or television
- Plug the equipment into a different branch circuit

NOTE: The manufacturer is not responsible for any radio or TV interference caused by unauthorized modifications to this equipment. Such modifications could void the user's authority to operate the equipment.

SPECIFICATIONS

Access

- Electronic Key Systems
- PABXs
- 1A2 Key Systems
- Stand Alone Systems

Refer to Figure 1 for a simplified block diagram of a typical installation.

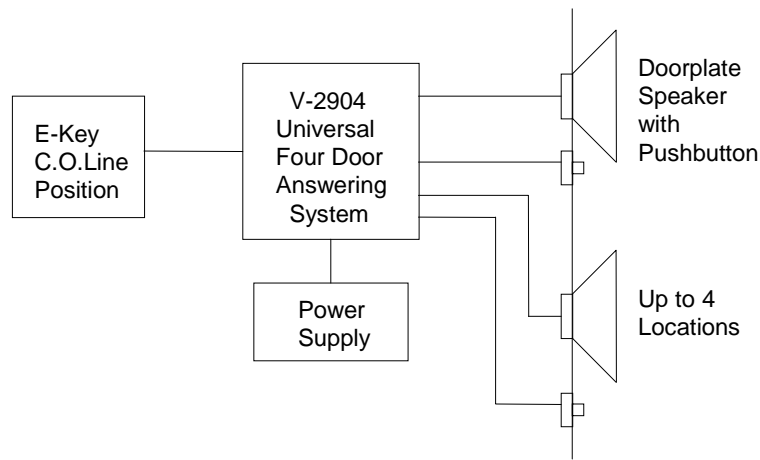

FIGURE 1 - SIMPLIFIED BLOCK DIAGRAM OF A TYPICAL INSTALLATION

Features

- Compatible with PABX, E-Key and 1A2 telephone
- Switch selectable - loop or ground start access
- Provides handsfree talkback to four separate locations
- RJ11 modular connector for Tip and Ring connections
- Power ON LED
- Provides contacts for up to four circuits
- Programmable options:
 - Programming access code
 - Ring Pattern
 - Station Identification
 - Activate lock relay
 - Duration of lock relay activation
 - Time door can remain open after unlock (exit delay time)
 - Entry delay time
 - Number of ring cycles
 - Disable station alarm
 - Alarm disable code
 - Station alert tone
- Input for manual door unlock (push button)
- Built-in 30Hz ring voltage generator with on/off switch
- Ringback tone to speaker
- Calls can be placed On Hold
- Call waiting
- One-way all call with volume control
- Background music input with volume control
- Speaker to phone volume control

- Phone to speaker volume control
- Simultaneous calls placed in queue
- Dial tone
- Confirmation tone
- Compatible with tone dial phones
- Works with Valcom V-1072A doorplate speaker or other Valcom one-way or talkback speakers.
- Compatible with VPB-260 battery backup

Dimensions/Weight

Dimensions: 8.60" H x 11.00" W x 2.30" D
(21.84cm H x 27.94cm W x 5.84cm D)
Weight: 3.1 lbs. (1.41 kg)

Nominal Specifications

Input Impedance: 600 Ohms
Input Level: -10dBm Nominal
Output Impedance: 45 Ohms
Ring Supply: 90VAC, 30Hz
Suitable for REN of 5.0

Power Requirements

Power Supply: -24VDC filtered
600mA minimum

Environment

Temperature: 0 to 40°C
Humidity: 0 to 85% (non-precipitating)

Components

The following equipment is recommended when using the V-2904:

- 1 - V-2904 Universal Four Door Answering System
- 1 - C. O. Line Position (Electronic Key System); 1 - Loop Trunk Position (PABX) or 1 - 400 type line card (1A2 key)
- 1 - Dedicated single line phone*
- 1 to 4 Valcom Doorplate Speaker(s)**
- 1 - VP-624B Power Supply

*** A single line telephone cannot be connected to both the V-2904 and an incoming central office line.**

**** It is recommended that one talkback speaker be used per door station. Use of more than one talkback speaker per station may result in damage to the V-2904. Up to 40 one-way amplified speakers may be connected to a zone if the zone is to be used as a one-way paging zone.**

DESIGN

The V-2904, Universal Four Door Answering System was designed to provide voice paging with handsfree reply to up to four door speakers from a telephone location. The V-2904 initiates ring-in on the telephone system and sends a confirmation tone to the door when a button is pressed at the door (Valcom doorplate speakers are normally used in this application). The individual at the phone responding to the signal can converse with the person at the door and determine if access should be allowed. If the door is equipped with an electric strikeplate, the person at the phone can enter a programmed code on the telephone dial pad or press a remote button to unlock the door to allow admission. When the system is in use and another call is placed from a different station, the person on the telephone will hear a call waiting tone corresponding to that door location. (Example: Beep-Beep for Station 2). The call will remain waiting for a programmed period of time. If this additional call remains unanswered, it will drop off after the programmed period of time for call waiting.

The V-2904 provides an alarm control output for unauthorized entry. When the door lock relay is activated and the door remains open longer than the programmed period of time, a ground potential will appear on pin 3 of the V-2904 (unauthorized door opening) that can be used to signal a customer provided alarm, auto dialer, etc. Also, if the phone is on hook, the phone will begin ringing in a pattern designating which door failed to close. (Example: Station 3 - ring-ring-ring). If the phone is off hook,

any activity the phone is involved in will be terminated and the phone will receive a momentary warble tone, a station indication tone, the ringback tone and be connected to the station with an open door. After hangup, if the door is not closed, the alarm condition will continue. If another unauthorized entry is detected, it will override the older one. When this new alarm condition is resolved, the system will revert to the previous alarm condition until all alarm conditions are resolved.

When indication arrives that a door is open while door station is inactive, such as a break-in, the system waits the programmed period of time (entry delay time) for a confirmation of entry indicating the opening as legitimate. When this does not arrive in the programmed time frame or if it arrives and the door is not closed at the end of the programmed time period, an alarm will sound in the same manner as described above.

The V-2904 also provides a background music input and is designed to automatically cut off at individual stations during a page or during an alarm situation. If background music is to be installed, a low level music source such as the Valcom V-2952 FM Tuner will be required.

Another feature of the V-2904 is the All Call Page. By pressing the number "8" or "0" on the telephone dialpad, the person at the phone can make a one-way announcement to all stations. The All Call is also overridden during an Alarm Condition.

INSTALLATION

Cabling

A 25 pair cable with a female amphenol connector should be run from the V-2904 to a 66B-type punchdown block. The cables should be terminated on the connecting block in standard color code. Refer to Figure 2 - Block Connections for the suggested pinout locations.

Mounting

The V-2904 is designed to be wall or shelf mounted. When wall mounting the V-2904, secure the unit to wall studs or a suitable brace, away from heat sources or strong magnetic fields (motors, fans, power supplies, etc.) with controls and connectors accessible. (A plywood backboard 2 feet square and at least 1/2 inch thick attached to wall studs would be considered a suitable brace).

Four #10 x 3/4 inch flat-head wood screws are included for mounting. Fasten two screws on the mounting surface, allowing them to protrude 1/8 inch to 1/4 inch. Place the chassis of the V-2904 onto the screwheads at the mounting slots.

Position the remaining screws and fasten through the remaining mounting slots. Tighten screws.

Connections

NOTE: The V-2904 could be used with equal success at a doorway, gateway, window, secure room or combination of these just to name a few possible applications. The term station is used to designate a location. Station 1 is used when describing connections; all other stations would be connected similarly. Refer to Figure 2 for pinouts of the specific station location.

Mount a 66B-type punchdown block on the backboard near the V-2904 Universal Four Door Answering System and label the block per Figure 2.

Move slide switch SW2 on the V-2904 to the appropriate location, Loop or Ground Start, (see Figure 3) depending on how the V-2904 is accessed.

If a modular cord is used for Tip and Ring connections, start at step ONE. For 66 block connections start at step TWO.

- ___ 1. Connect one end of the modular cord to the V-2904 RJ11 and the other end to the appropriate line position of the phone system. Go to step 3.
- ___ 2. Connect Tip of the key system line position, loop or ground start trunk, to Pin 26 (W/BL) and Ring to Pin 1 (BL/W).
- ___ 3. Connect Tip of Zone 1 45 Ohms talkback speaker to pin 32 (R/O) and Ring to pin 7 (O/R).
- ___ 4. If using a door button with the Zone 1 talkback speaker, connect normally open, single pole push button switch to Door Button 1 connection pin 33 (R/G) and pin 9 (BR/R) Ground. (Figure 5 depicts a typical speaker/door button hookup).
- ___ 5. Move slide switch SW1 (located on the V-2904 board) to the ON position if the telephone system is to ring when the door button is pressed. (Refer to Figure 3 for location).

- ___ 6. Connect the -24VDC power supply. -24VDC should be connected to pin 25 (S/V) and Ground connected to pin 50 (V/S). The power LED located on the V-2904 board should illuminate.

Battery Backup

A Valcom VPB-260 Battery Backup may be added to the system to provide power in case of power failure.

The VPB-260 plugs directly into the V-2904. Figure 4 shows the appropriate connection. The VPB-260 should be allowed to charge for approximately 9 hours before operating the V-2904. **The Valcom VPB-260 battery backup may be used as the sole supply of power to the V-2904.**

Remote Door Unlock Relay

Figure 6 shows the V-2904 contact arrangement available for electric strike plate operation.

Before connecting an electric lock to the V-2904, consult the manufacturer instructions for the proper connecting arrangement.

Remote Push Button for Manual Door Release

A momentary, normally open, single-pole, single-throw switch can be connected to the system. Suggested pinouts to the 66B-type block are shown in Figure 7. Again, refer to manufacturer instructions for proper connections. The remote button should be placed in an inconspicuous location to provide a more secure system.

NOTE: If the remote button does not respond, you have most likely entered a confirmation press. Additional presses will result in an alarm condition.

Handsfree Indicator ("Station Outputs")

The V-2904 supplies connections to allow handsfree indicators to be connected to the system. No indication is available during All Call. During handsfree communication, with station 1, pin 6 goes to -24VDC when connected as shown in Figure 8. Maximum current available is 50mA. Other station outputs react in a similar manner.

FIGURE 2 - BLOCK CONNECTIONS

Tip	W/BL	26
Ring	BL/W	1
Common Audible Make	W/O	27
Common Audible Stationary	O/W	2
Common Audible Break	W/GR	28
Unauthorized Door Opening	GR/W	3
Background Music Tip	W/BR	29
Background Music Ring	BR/W	4
Door 1 Unlock Make	W/S	30
Door 1 Unlock Stationary	S/W	5
Door 1 Unlock Break	R/BL	31
Station 1	BL/R	6
Handsfree Speaker 1 Tip	R/O	32
Handsfree Speaker 1 Ring	O/R	7
Door Button 1	R/G	33
Remote 1	G/R	8
Door Sensor 1	R/BR	34
Ground 1	BR/R	9
Door 2 Unlock Make	R/S	35
Door 2 Unlock Stationary	S/R	10
Door 2 Unlock Break	BK/BL	36
Station 2	BL/BK	11
Handsfree Speaker 2 Tip	BK/O	37
Handsfree Speaker 2 Ring	O/BK	12
Door Button 2	BK/G	38
Remote 2	G/BK	13
Door Sensor 2	BK/BR	39
Ground 2	BR/BK	14
Door 3 Unlock Make	BK/S	40
Door 3 Unlock Stationary	S/BK	15
Door 3 Unlock Break	Y/BL	41
Station 3	BL/Y	16
Handsfree Speaker 3 Tip	Y/O	42
Handsfree Speaker 3 Ring	O/Y	17
Door Button 3	Y/G	43
Remote 3	G/Y	18
Door Sensor 3	Y/BR	44
Ground 3	BR/Y	19
Door 4 Unlock Make	Y/S	45
Door 4 Unlock Stationary	S/Y	20
Door 4 Unlock Break	V/BL	46
Station 4	BL/V	21
Handsfree Speaker 4 Tip	V/O	47
Handsfree Speaker 4 Ring	O/V	22
Door Button 4	V/G	48
Remote 4	G/V	23
Door Sensor 4	V/BR	49
Ground 4	BR/V	24
Power Supply GND	V/S	50
Power Supply -24VDC	S/V	25

Figure 3 - Connector and Control Locations

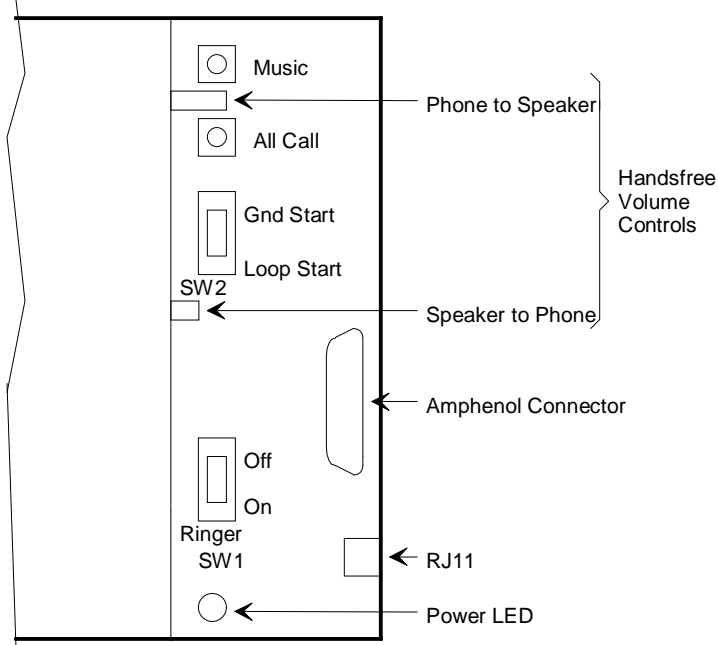
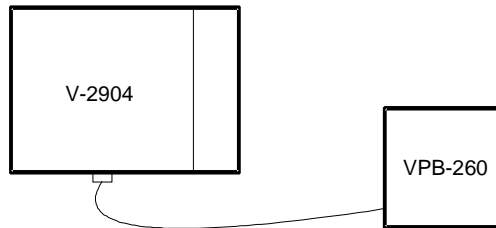

Figure 4 - Battery Backup



TYPICAL APPLICATIONS

Figure 5 - Doorplate Speaker with Pushbutton

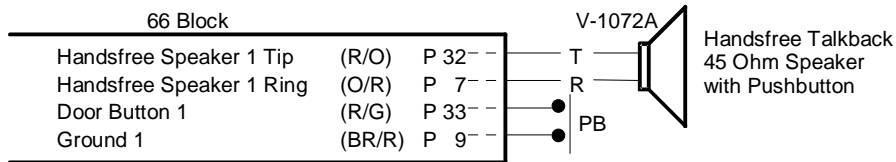
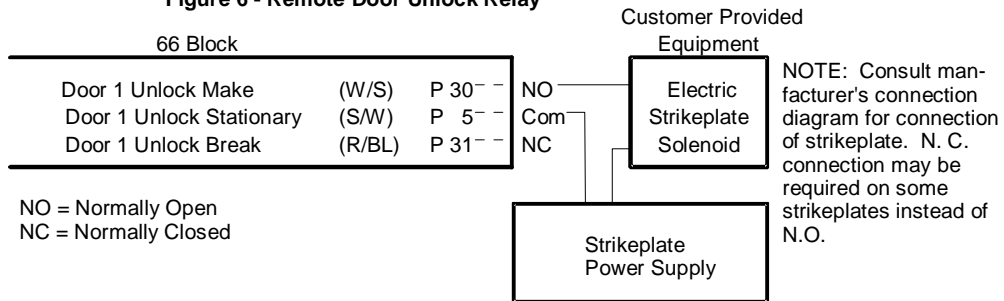

Figure 6 - Remote Door Unlock Relay



TYPICAL APPLICATIONS (Continued)

Figure 7 - Remote/Confirmation Pushbutton for Manual Door Release

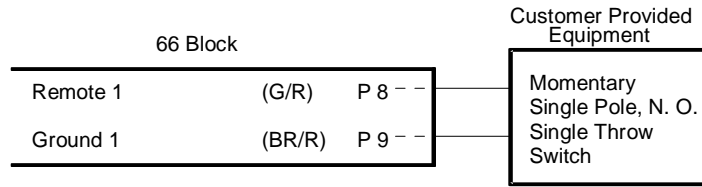

Figure 8 - Handsfree Indicator

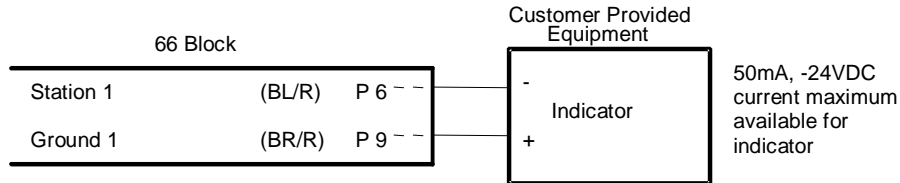

Figure 9 - Door Sensor

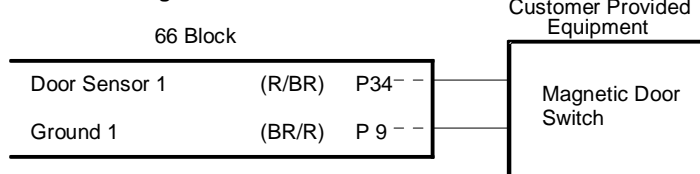

Figure 10 - Unauthorized Door Opening

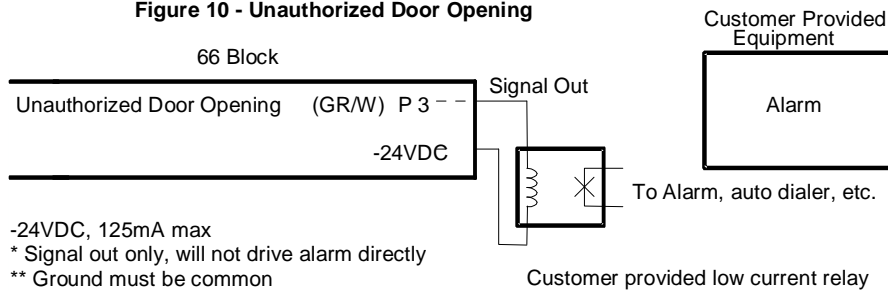
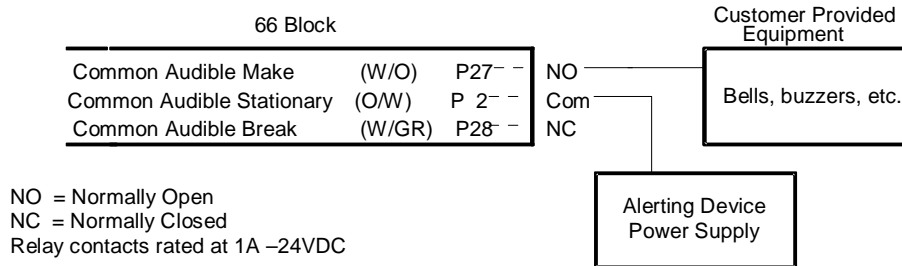

Figure 11 - Remote Signalling Relay



Door Sensor

When this contact is shorted (by opening the door, gate, etc.) without a legitimate dialpad or remote key press opening, this will initiate an alarm condition. Refer to Figure 9 for typical connections.

Unauthorized Door Opening

During an alarm state, UDO (unauthorized door opening) goes to ground, to signal a customer provided alarm that an alarm condition exists. Refer to Figure 10 for typical connections.

Remote Signaling (Alerting Device)

The V-2904 supplies contacts to allow an alerting device to be connected to the system. These contacts follow the ringing cycle and can be used to operate a remote signaling device such as a bell, buzzer or light. One device provides alert indication for the entire system. Refer to Figure 11 for a typical connection using these contacts.

Background Music Connections

Connect the low level (-10dBm nominal) output of a music source to pin 29 (W/BR) and pin 4 (BR/W) of the 66 block. Adjust input of the music source to a minimum. Volume of the background music will be regulated by the volume control of the V-2904.

Volume Adjustments

There are four volume controls on the V-2904. See Figure 3 for location of these controls.

- ___ 1. Phone to Speaker: Adjusts speaker volume.
- ___ 2. Speaker to Phone: Adjusts talkback volume from the speaker. **IMPORTANT: Set this volume at the lowest practical level. Setting this control too high will increase background noise without giving greater talkback volume.**
- ___ 3. All Call: Adjusts volume of all call announcements at the doorplate speaker.
- ___ 4. Music: Adjusts Background Music volume at the door speaker.

PROGRAMMING

General

NOTE: The V-2904 can be accessed via tone dial systems and programming must be performed with a tone dial set.

The V-2904 is designed to allow the user to program its functions to meet the requirements of the specific application. The V-2904 is, however, shipped from the factory with all functions pre-set to default settings. These default settings are listed in the Program Chart.

It is strongly recommended that the default settings be changed to suit the needs of the situation. The settings of the Access Code and Door Unlock Code, particularly, should be changed to provide a more secure system.

The following instructions explain the procedures required to program the codes for the V-2904. Individual codes can be programmed per feature for each station or per feature for the total system. After each program change, a dial tone will be received designating a proper entry.

Master Access Code

The Master Access Code allows entry to programming as well as to the use of the system. **It is essential that this code remain confidential to maintain the security of the system. The Access Code can be 1 to 7 digits in length. The asterisk (*) or number (#) signs can not be used in the access code.**

The default master access code is 1 2 3. To change this code:

1. Lift handset and hear dial tone.
2. Press # # # on the dial pad.
3. Enter the old access code on the dial pad.
4. Press * * * on the dial pad.
5. Enter the new access code on the dial pad.
6. Press * * * again.
7. Will receive dial tone if programmed correctly.

Programming Functions

The following program instructions show the access code for each function as 1 2 3. If a new master access code is programmed prior to programming the following functions, the new access code would be substituted where the 1 2 3 is shown.

These following codes cannot contain # as part of their code.

Ring Pattern

When the doorplate button at a station is pressed, the V-2904 initiates ring-in on the telephone system. There are three ring patterns available.

- 2 seconds on, 4 seconds off (American ring)
- 2 bursts in 2 seconds, 2 seconds off (British ring)
- 1 second on, 4 seconds off (Dutch ring)

To change the ring pattern:

American Ring (default)

1. Lift handset and hear dial tone.
2. Press # 1 2 3 * 5 on the dial pad.
3. Press #, receive dial tone.

British Ring

1. Lift handset and hear dial tone.
2. Press # 1 2 3 * 6 on the dial pad.
3. Press #, receive dial tone.

Dutch Ring

1. Lift handset and hear dial tone.
2. Press # 1 2 3 * # on the dial pad.
3. Press #, receive dial tone.

NOTE: The common audible relay contacts follow the ringing cadence with the exception of British Ring. In British Ring mode, the contacts close at the beginning of the first burst and remain closed until the end of the second burst.

Station Identification

When a door button is pressed, it activates the phone to ring. When the phone is answered, ringing is removed and the phone may or may not receive a station identification tone (depending on how programmed).

Station ID Tone Always Generated (default)

1. Lift handset and hear dial tone.
2. Press # 1 2 3 * 7 on the dial pad.
3. Press #, receive dial tone.

Station ID Tone Generated when Station in Alarm Condition

1. Lift handset and hear dial tone.
2. Press # 1 2 3 * 8 on the dial pad.
3. Press #, receive dial tone.

Station ID Tone Generated for Calls from Non Alarm Stations only

1. Lift handset and hear dial tone.
2. Press # 1 2 3 * 9 on the dial pad.
3. Press #, receive dial tone.

Station ID Tone Never Generated

1. Lift handset and hear dial tone.
2. Press # 1 2 3 * 0 on the dial pad.
3. Press #, receive dial tone.

Activate Lock Relay (Door Unlock)

This code would be used to operate the door unlock contacts which can be used to open an electric lock used at a doorway or gate. The default access code to activate the lock relay is *. This code can be from 1 to 7 digits and the asterisk (*) sign can be programmed in this code if desired.

To change this code:

1. Lift handset and hear dial tone.
2. Press # 1 2 3 # on the dial pad.
3. Enter station number (1-4) or * for all stations.
4. Enter up to 7 digits.
5. Press #.
6. Receive dial tone.

Duration of Lock Relay Activation

This function determines the length of time the lock relay remains activated after dialing the door unlock code. The default equals 2 seconds. The length of time the lock relay remains activated can be from 1 to 99 seconds depending on the specific situation. However, once an opening and closing of a door takes place, the unlock relay will release prior to the expiration of the programmed period preventing further entries.

To change this default setting:

1. Lift handset and hear dial tone.
2. Press # 1 2 3 # 6 on the dial pad.
3. Enter station number (1-4) or * for all stations.
4. Enter the number of seconds the lock should remain activated (1-99).
5. Press #.
6. Receive dial tone.

Time Door May Remain Open after Unlock before Alert (this period of time also sets the exit delay time)

The length of time the door or gate should remain open will vary depending on the actual application. A drive-through gate may require a longer time than a walk-through door. If, for some reason, the opening does not close by the designated period of time, an alarm condition will occur (see Operation). The possible programmed time for a door to remain open can be from 0 to 999 seconds. The default for this function is 15 seconds. This default is changed by:

1. Lift handset and hear dial tone.
2. Press # 1 2 3 # 7 on the dial pad.
3. Enter station number (1-4) or * for all stations.
4. Enter the number of seconds the door should remain open (0-999).
5. Press #.
6. Hear dial tone.

Entry Delay Time

If a key entry occurs at a door (an entry not using the dialpad or remote button) the remote button must be pressed or the confirmation code must be dialed on the telephone keypad. This must be done within a designated period of time after the door is opened signifying a legitimate door opening or an alert will sound. The default time for the confirmation press is 15 seconds. This time can be changed by:

1. Lift handset and hear dial tone.
2. Press # 1 2 3 # 8.
3. Enter station number (1-4) or * for all stations.
4. Enter time length in seconds (0-999).
5. Press #.
6. Receive dial tone.

Duration of Ringing

When a door button is pressed, it activates the phone into a ring cycle. The ring cycle will continue for a programmed time period and stop if unanswered.

The default equals approximately 30 seconds. To change this default:

1. Lift handset and receive dial tone.
2. Press # 1 2 3 # 5.
3. Enter station number (1-4) or * for all stations.
4. Enter ringing duration (1-255 seconds)
(0 = no time out)
5. Press #.
6. Receive dial tone.

Disable Station Alarm

On power up, the station alarm condition is active. In the event a doorway or gate would need to be left open for an extended time (or at least longer than the programmed time it can remain open before an alarm condition), the alarm can be disabled.

To leave door open without causing an alarm condition:

1. Lift handset and receive dial tone.
2. Press 5.
3. Press station number (1-4) to be disabled or * for all stations.
4. Enter disable code (default is *; this may have been changed).
5. Receive dial tone.

The default code for disabling the station alarm condition is *. To change this default:

1. Lift handset and hear dial tone.
2. Press # 1 2 3 # *.
3. Enter station number (1-4) or * for all stations.
4. Enter up to 7 digits.
5. Press #.
6. Receive dial tone.

NOTE: When a disabled station is accessed, the alert tone will be at a lower tone as a reminder that the alarm at that station has been disabled.

To enable a door alarm that has been disabled:

1. Lift handset and receive dial tone.
2. Press 6.
3. Press station number (1-4) or * for all stations.
4. Receive dial tone.

Alert Tone

The phone and station receives a ringback tone prior to connection. Default - the station receives the tone.

To remove the alert tone:

1. Lift handset and receive dial tone.
2. Press # 1 2 3 # 9.
3. Enter station number (1-4) or * for all stations.
4. Press 0.
5. Press #.
6. Receive dial tone.

To re-activate the alert tone:

1. Lift handset and receive dial tone.
2. Press # 1 2 3 # 9.
3. Enter station number (1-4) or * for all stations.
4. Press 1.
5. Press #.
6. Receive dial tone.

Door Detect

Some door alarm contacts are closed when the door is closed and some are open when the door is closed.

By default, the V-2904 uses door alarm contacts that are open when the door is closed.

To change this default:

1. Lift handset and receive dial tone.
2. Press # 1 2 3 # 0 1.
3. Press # and receive dial tone.

OPERATION

When the doorplate button at a station is pressed, interrupted ring voltage from the V-2904 initiates ring-in on the telephone system and sends a confirmation tone to the door. When the phone is answered, a series of optional tones may be heard in the receiver. These tones numerically indicate which door is calling. These are followed by a ringback tone and connection to the handsfree speaker. When the phone is busy with one station and a call is placed from another station, the person on the telephone will hear a call waiting tone corresponding to the door location. (Example: Station 2 - Beep-Beep). Repeated button presses from the station will cause repeated signals to the phone provided the presses are separated by 5 seconds. If the 2nd call is not answered during the programmed time (determined by the programmed number of ring cycles) after the last press, it will lose its power to be answered. If the door is equipped with an electric strikeplate, a

code can be dialed from the phone to operate the relay to unlock the door. The lock relay will remain open for a programmed period of time. A normally open, single-pole push button switch can also be connected to the V-2904 to manually operate the door unlock relay. The lock relay will remain open as long as the remote button is held (maximum 99 seconds) plus the programmed period of time.

If the door remains open longer than the programmed time after the lock relay has closed and a customer supplied door sensor is provided, an alarm condition will occur. If on hook, the phone will begin ringing in a pattern indicating which door failed to close. When answered, the phone will receive a momentary warble tone, tones indicating location, the ringback indication and be connected to the station. If off hook, any activity the phone is involved in will cease and the phone will receive the same sequence of tones as mentioned previously and be connected to the station. After hang up, in both instances, if the door is not closed, the alarm condition will continue. If another unauthorized entry is detected, it will override the older one. When this new alarm condition is resolved, the system will revert to the previous alarm condition until all alarm conditions are resolved.

When an indication arrives that a door is open while the door station is inactive, (example: a break-in) the system waits the programmed period of time for a confirmation of entry, if the confirmation of entry is not received, the unauthorized entry alert will take place as described previously.

Confirmation of Entry

When a key entry is made (an entry not using the dialpad or remote button), either the remote button must be pressed (a confirmation press) within the programmed period of time after the door is opened or the telephone can be used to dial the appropriate confirmation of entry. To confirm an entry by phone:

1. Lift handset and receive dial tone.
2. Enter the door number and appropriate door unlock code.

A confirmation press or entering the unlock code via telephone to signify a legitimate door opening must take place before the programmed period of time ends or an alarm condition will occur.

NOTE: The remote button can be used for a confirmation press or to activate the lock relay (door unlock).

Call Waiting

If the phone is connected to station 1 in a conversation and station 2 attempts, by pressing the door button, to call in, the individual at the phone will receive a call waiting indication. The indication will

be received as tones designating the station number trying to call in (example: Station 2 - beep, beep). Repeated door button presses from that station will cause repeated indications to the phone provided the presses are separated by 5 seconds. If the second call is not answered within the programmed number of ring cycles, the call waiting condition will time out.

To answer call waiting, first receive dial tone by pressing # or placing active station "on hold" (see "Station On Hold" Section). Then dial station corresponding to location of call waiting indication. Another way of answering call waiting is to go "on hook" with phone and let the call ring in.

NOTE: The call waiting duration corresponds to the number of ring cycles generated when the door button is pressed (see Section titled "Duration of Ringing" page 10).

Exiting without Alarm Activation

1. Lift handset and receive dial tone.
2. Dial station to be used for exit and enter unlock code or press manual door unlock push button for desired station.
3. Exit door of station within the programmed exit delay time.

Call Out from the Phone

The single line telephone, C. O. line position, loop or ground start trunk used with the V-2904 is dedicated to the communications and to features accessed within the V-2904 system. The phone can be used to access individual stations by pressing the number corresponding to the desired station. (example: 1 for door 1, 2 for door 2, etc.). A ringback tone (optional) will be generated prior to connection to a station. Pressing the number "8" or "0" on the telephone dialpad, a person at the phone can make a one-way announcement to all stations. A ringback tone is received in the handset preceding connection to the all call circuit.

A telephone connection to a station can be terminated by hanging up or flashing the switchhook. Dial tone returns after each of these actions.

All Call "Meet Me"

A single press at a station during an all call page will terminate the all call and connect the phone to the station where the press occurred. While the phone is talking to this station via the "Meet Me" page, two presses (within one second of each other from another station) will end the original "Meet Me" connection and send the phone to the new station in a "Meet Me" page.

Station On Hold

Calls can be placed on hold by pressing the

switchhook. This press should be a flash of less than one second. Holding the switchhook down for a longer period will disconnect the call.

TECHNICAL ASSISTANCE

When trouble is reported, make certain there are no broken connections leading to this system. Table 1 identifies some possible problems with solutions.

Assistance in troubleshooting is available from the factory. When calling, you should have a VOM and a telephone test set available and call from the job site.

Call (540) 563-2000 and press 1 for Technical Support or visit our website at <http://www.valcom.com>.

VALCOM equipment is not field repairable. VALCOM maintains service facilities in Roanoke, VA. Should repairs be necessary, attach a tag to the unit clearly stating your company name, address, phone number, contact person and the nature of the problem. Send the unit to:

Valcom, Inc.
Repair and Return Dept.
5614 Hollins Road
Roanoke, VA 24019-5056

USER GUIDE

FUNCTIONS	ACTIONS
Call a Station	Dial Station Number (1-4).
Unlock Door	Dial Station Number then dial unlock code (or press remote push button).
All Call	Dial 8 or 0.
Disable Alarm	Dial 5, then station number to be disabled or * for all stations, then dial alarm disable code.
Enable Alarm	Dial 6, then station number to be enabled or * for all stations.
Exiting with Alarm On	Access station used for exit then dial unlock code (or press remote push button), then exit door within exit delay time.
Entering with Alarm On	Enter door, then dial the station number of door entered and the appropriate door unlock code (or press door's remote push button) within entry delay time.

TABLE 1 - TROUBLESHOOTING CHART

PROBLEMS	ACTIONS
<ul style="list-style-type: none"> • No system operation; Power LED not lit. • No system operation; power LED is lit. • No paging at speaker. • Paging at speaker but no reply from speaker. • No system ringing when doorplate button pressed. • Door unlock relay does not operate. • Door strike does not operate. 	<ul style="list-style-type: none"> • Verify power from power supply. • Verify that 25 pair connector is completely plugged into circuit board connector. • Verify all connections. • Check doorplate speaker connections. • Adjust Phone to Speaker volume. • Adjust Speaker to Phone volume. • Check Ring "ON/OFF" switch. • Check connections at block. • Verify proper access code. • Do you have a power supply for your door strike? (See Figure 6).

VALCOM LIMITED WARRANTY

Valcom, Inc. warrants its products only to the original purchaser, for its own use, to be free from defects in materials and workmanship under conditions of normal use and service for a period of one year from the date of shipment. This Limited Warranty obligation shall be limited to the replacement, repair or refund of any such defective device within the warranty period, provided that:

1. inspection by Valcom, Inc. indicates the validity of the claim;
2. the defect is not the result of damage, misuse or negligence after the original shipment;
3. the product has not been altered in any way or repaired by others and that factory sealed units are unopened (a service charge plus parts and labor will be applied to units defaced or physically damaged);
4. freight charges for the return of products to Valcom are prepaid;
5. all units 'out of warranty' are subject to a service charge. The service charge will cover minor repairs (major repairs will be subject to additional charges for parts and labor).

This Limited Warranty is in lieu of and excludes all other warranties, expressed or implied and in no event shall Valcom, Inc. be liable for any anticipated profits, consequential damages, loss of time or other losses incurred by the buyer in connection with the purchase, operation, maintenance, installation, removal or use of the product. The maximum liability of Valcom under this warranty is limited to the purchase price of the specific Product covered by the warranty.

Disclaimer. Except for the Limited Warranty provided herein, the product is provided "as-is" without any warranty of any kind whatsoever including, without limitation, any **WARRANTY OF MERCHANTABILITY, FITNESS FOR A PARTICULAR PURPOSE OR NON-INFRINGEMENT.**

This warranty specifically excludes damage incurred in shipment. In the event a product is received in damaged condition, the carrier should be notified immediately. Claims for such damage should be filed with the carrier involved in accordance with the F.O.B. point.

Headquarters:

Valcom, Inc.

5614 Hollins Road Roanoke, VA 24019-5056

Phone: (540) 563-2000 FAX: (540) 362-9800

PROGRAM CHART - RECORD AND FILE IN A SECURE PLACE

Function	Default	Reprogram	Parameter	New Program
Master Access Code (MAC)	1 2 3	###123*** _____***	7 digits excluding # and *	
Ring Pattern American Ring British Ring Dutch Ring	American Ring	# MAC * 5 # MAC * 6 # MAC * #		
Station Identification ID beeps always generated ID beeps when alarm condition ID beeps non-alarm condition No ID Beeps	ID beeps always generated	# MAC * 7 # MAC * 8 # MAC * 9 # MAC * 0		
Activate Lock Relay Sta 1 Sta 2 Sta 3 Sta 4	* * * *	Sta 1 # MAC #1 _____ # Sta 2 # MAC #2 _____ # Sta 3 # MAC #3 _____ # Sta 4 # MAC #4 _____ # All Doors # MAC #* _____ #	7 digits including *	Sta 1 Sta 2 Sta 3 Sta 4
Duration of Lock Relay Activation Sta 1 Sta 2 Sta 3 Sta 4	2 sec 2 sec 2 sec 2 sec	Sta 1 # MAC #61 _____ # Sta 2 # MAC #62 _____ # Sta 3 # MAC #63 _____ # Sta 4 # MAC #64 _____ # All Doors # MAC #6* _____ #	1-99 in seconds	Sta 1 Sta 2 Sta 3 Sta 4
Time Door May Remain Open After Unlock Before Alert (Exit Delay Time) Sta 1 Sta 2 Sta 3 Sta 4	15 sec 15 sec 15 sec 15 sec	Sta 1 # MAC #71 _____ # Sta 2 # MAC #72 _____ # Sta 3 # MAC #73 _____ # Sta 4 # MAC #74 _____ # All Doors # MAC #7* _____ #	0-999 in seconds	Sta 1 Sta 2 Sta 3 Sta 4
Entry Delay Time Sta 2 Sta 1 Sta 3 Sta 4	15 sec 15 sec 15 sec 15 sec	Sta 1 # MAC #81 _____ # Sta 2 # MAC #82 _____ # Sta 3 # MAC #83 _____ # Sta 4 # MAC #84 _____ # All Doors # MAC #8* _____ #	0-999 in seconds	Sta 1 Sta 2 Sta 3 Sta 4
Duration of Ringing Sta 2 Sta 1 Sta 3 Sta 4	30 sec 30 sec 30 sec 30 sec	Sta 1 # MAC #51 _____ # Sta 2 # MAC #52 _____ # Sta 3 # MAC #53 _____ # Sta 4 # MAC #54 _____ # All Doors # MAC #5* _____ #	1-255 sec 0 = no time out	Sta 1 Sta 2 Sta 3 Sta 4
Alarm Disable Code Sta 2 Sta 1 Sta 3 Sta 4	* * * *	Sta 1 # MAC *1 _____ # Sta 2 # MAC *2 _____ # Sta 3 # MAC *3 _____ # Sta 4 # MAC *4 _____ # All Doors # MAC ** _____ #	7 Digits	Sta 1 Sta 2 Sta 3 Sta 4
Alert Tone Sta 2 Sta 1 Sta 3 Sta 4	ON ON ON ON	Sta 1 On # MAC # 911 # Sta 2 On # MAC # 921 # Sta 3 On # MAC # 931 # Sta 4 On # MAC # 941 # Sta 1 Off # MAC # 910 # Sta 2 Off # MAC # 920 # Sta 3 Off # MAC # 930 # Sta 4 Off # MAC # 940 # All Doors Off # MAC #9*0# All Doors On # MAC #9*1#	OFF or ON	Sta 1 Sta 2 Sta 3 Sta 4
Door Detect Default		Sta 1 # MAC # 010 Sta 2 # MAC # 020 Sta 3 # MAC # 030 Sta 4 # MAC # 040	Door contact open when door is closed.	
Door Detect Reversed		Sta 1 # MAC # 011 Sta 2 # MAC # 021 Sta 3 # MAC # 031 Sta 4 # MAC # 041	Door contact closed when door is closed.	

INSTALLATION _____
INSTALLING COMPANY _____
INSTALLER _____ **DATE** _____

A proper programming sequence is followed by a dial tone - An improper programming sequence by a busy tone.