

## VIP-9831A IP Indoor Stealth Horn

### INTRODUCTION

The VIP-9831A IP Stealth Horn is a self-contained paging system which enables voice paging up to 300 feet from an Ethernet connection. The VIP-9831A consists of a horn and Network/Audio Interface board allowing stand alone capability when used with a SIP enabled telephone system or can be accessed from a variety of Valcom managed VoIP products.

### SPECIFICATIONS

#### Access Methods

- PBX, FXO Port w/VIP-811
- POTS telephone set w/VIP-811
- PBX, FXS Port w/VIP-821
- Valcom M Cast Page Group
- SIP telephone system

#### Features

- RJ-45 network connection
- Network activity LEDs
- Power over Ethernet (PoE) 802.3af compatible

#### Dimensions/Weight

- 9.3 "H x 15.0 "W x 5.0 "D  
(23.6 cm x 38.1 cm x 12.7 cm)
- Weight: 5.5 lbs (2.05 kg)
- Shipping Weight: 6.0 lbs (2.24kg)





#### Environment

- Temperature: 0 to +40° C
- Humidity: 0 to 85% non-precipitating
- **INDOOR USE ONLY**

#### Power

Via 802.3af PoE Ethernet Switch: Class 3

### Precautionary Designations

	<b>CAUTION</b> RISK OF ELECTRIC SHOCK DO NOT OPEN	
<p>CAUTION: To reduce the risk of electric shock, Do not remove cover. No user serviceable parts inside. Refer servicing to qualified service personnel.</p>		
	<p>This symbol indicates that dangerous voltage constituting a risk of electric shock is present within this unit.</p>	
	<p>This symbol indicates that there are important operating and maintenance instructions in the literature accompanying this unit.</p>	

### Packing List

Qty	Item
1	VIP-9831A IP Horn
1	VSP Document
4	Mounting Screws

### INSTALLATION

#### FCC Information

This equipment has been tested and found to comply with the limits for a Class A digital device, pursuant to Part 15 of the FCC Rules. These limits are designed to provide reasonable protection against harmful interference when the equipment is operated in a commercial environment. This equipment generates uses and can radiate radio frequency energy and if not installed and used in accordance with the instruction manual, may cause harmful interference to radio communications. Operation of this equipment in a residential area may cause harmful interference in which case the user will be required to correct the interference at his own expense.

#### IMPORTANT SAFETY INFORMATION

#### CONSIGNES DE SÉCURITÉ IMPORTANTES

1. Read these instructions.  
*Lisez ces instructions.*
2. Keep these instructions.  
*Conservez ces instructions.*
3. Heed all warnings.  
*Respectez tous les avertissements.*
4. Follow all instructions.  
*Suivez toutes les instructions.*
5. Do not use this apparatus near water.  
*Ne pas utiliser cet appareil près de l'eau.*
6. Clean only with dry cloth.  
*Nettoyer avec un chiffon sec.*
7. Do not block any ventilation openings. Install in accordance with the manufacturer's instructions.  
*Ne pas bloquer les ouvertures de ventilation. Installer conformément aux instructions du fabricant.*
8. Do not install near any heat sources such as radiators, heat registers, stoves or other apparatus (including amplifiers) that produce heat.  
*Ne pas installer à proximité de sources de chaleur telles que radiateurs, registres de chaleur, poêles ou autres appareils (y compris les amplificateurs) produisant de la chaleur.*
9. Do not defeat the safety purpose of the polarized or grounding-type plug. A polarized plug has two blades with one wider than the other. A grounding type plug has two blades and a third grounding prong. The wide blade and the third prong are provided for your safety. If the provided plug does not fit into your outlet consult an electrician for replacement of the obsolete outlet.  
*Ne pas contourner le dispositif de sécurité de la fiche polarisée ou de mise à la terre. Une fiche polarisée possède deux lames dont une plus large que l'autre. Une fiche de terre a deux lames et une troisième broche de mise à la terre. La lame large et la troisième broche sont fournies pour votre sécurité. Si la fiche fournie ne rentre pas dans votre prise, veuillez consulter un électricien pour le remplacement de la prise obsolète.*
10. Protect the power cord from being walked on or pinched particularly at plugs, convenience receptacles and the point where they exit from the apparatus.
11. Only use attachments/accessories specified by the manufacturer.  
*N'utilisez que des fixations / accessoires spécifiés par le fabricant.*
12. Use only with the cart, stand, tripod, bracket or table specified by the manufacturer or sold with the apparatus. When a cart is used, use caution when moving the cart/apparatus combination to avoid injury from tip-over.  
*Utilisez uniquement avec le chariot, stand, trépied, support ou table spécifié par le fabricant ou vendu avec l'appareil. Quand un chariot est utilisé, Soyez prudent lorsque vous déplacez l'ensemble chariot / appareil pour éviter des blessures dues au renversement.*
13. Unplug this apparatus during lightning storms or when unused for a long period of time.  
*Débranchez cet appareil pendant les orages ou lorsqu'il n'est pas utilisé pendant une longue période de temps.*
14. Refer all servicing to qualified service personnel. Servicing is required when the apparatus has been damaged in any way. Such as when the power supply cord or plug is damaged, liquid has been spilled, objects have fallen into the apparatus or the apparatus has been exposed to rain or moisture and does not operate normally or has been dropped.  
*Confiez toute réparation à un personnel qualifié. Une réparation est nécessaire lorsque l'appareil a été endommagé de quelque façon. Par exemple lorsque le cordon d'alimentation ou la fiche est endommagé, du liquide a été renversé, si des objets sont tombés dans l'appareil ou le appareil a été exposé à la pluie ou à l'humidité et ne fonctionne pas normalement ou s'il est tombé.*



## Status Indicator Lights

The VIP-9831A has 2 status indication lights located on network jack:

**Green LED: (Link)** Indicates Ethernet connection when illuminated.

**Yellow LED: (Activity)** Indicator flashes to indicate network activity.

## Operation

Provide paging from SIP connection or via a variety of Valcom managed VoIP products. Integration to customer telephone system can be via SIP registration, FXO port (with VIP-811), or FXS port (with VIP-821).

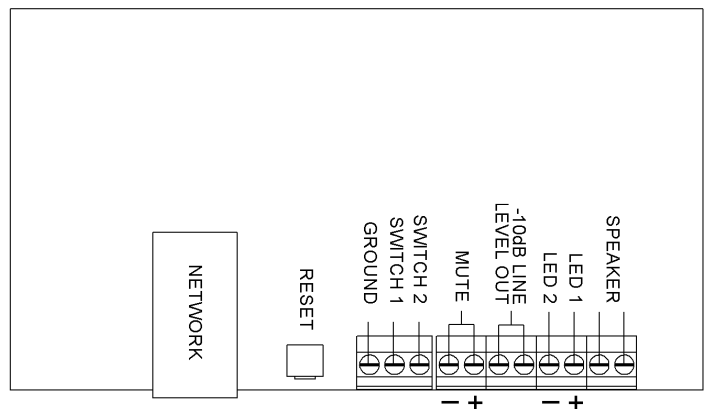

Figure 1. Connections

## Mounting (Enclosure / Horn)

The horn should be mounted 8 to 12 feet above the floor to allow for best sound distribution. This unit can be mounted to a single gang, double gang, octagon electrical box or wall. See to Figure 2.

- Using a Phillips screwdriver, remove 4 screws attaching grille to enclosure base.
- Using a 11/32 nut driver, carefully remove horn bracket assembly from enclosure base. Do not remove horn from bracket.
- Carefully disconnect the black and white speaker wires from Network/Audio PC board
- Mount enclosure base to wall using appropriate hardware.
- Reconnect black and white speaker wires to Network/Audio PC board.
- Install horn bracket assembly.
- Connect 802.3af compliant PoE port (300 feet maximum distance) to network connector on Network/Audio PC board.
- Install grille onto enclosure base.

## Setup

Information specific to your application will need to be programmed into the VIP-9831A using a computer. Setup will be done using the IP Solutions Setup Tool. The IP Solutions Setup Tool may be downloaded from the Valcom website at [www.valcom.com/vipsetuptool](http://www.valcom.com/vipsetuptool).

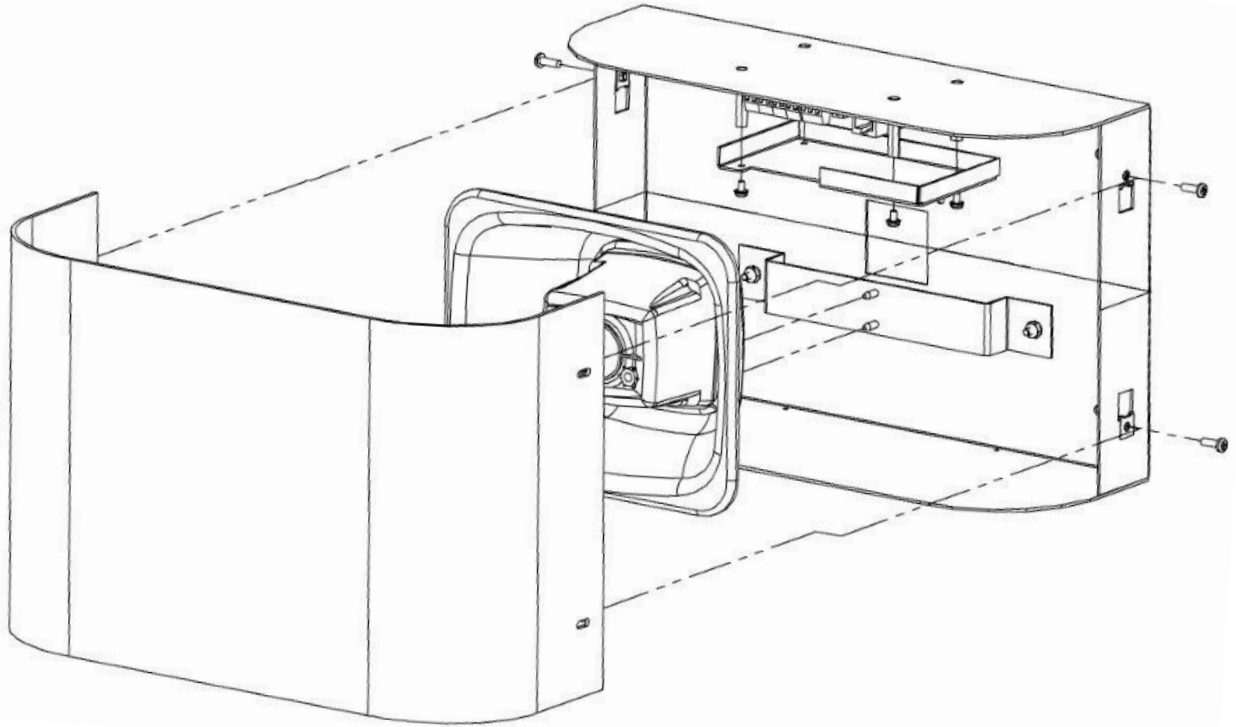

**Figure 2. Mounting**

## TECHNICAL ASSISTANCE

Assistance is available from the factory when problems are encountered. Call (540) 563-2000 and press 1 for Technical Support or visit our website at <http://www.valcom.com>.

Valcom equipment is not field repairable. Valcom, Inc. maintains service facilities in Roanoke, VA. Should repairs be necessary, attach a tag to the unit clearly stating your company name, address, phone number, contact person and the nature of the problem. Send the unit to:

**Valcom, Inc.  
Repair & Return Dept.  
5614 Hollins Road  
Roanoke VA. 24019**

### VALCOM LIMITED WARRANTY

Valcom, Inc. warrants its products only to the original purchaser, for its own use, to be free from defects in materials and workmanship under conditions of normal use and service for a period of one year from the date of shipment. This Limited Warranty obligation shall be limited to the replacement, repair or refund of any such defective device within the warranty period, provided that:

1. inspection by Valcom, Inc. indicates the validity of the claim;
2. the defect is not the result of damage, misuse or negligence after the original shipment;
3. the product has not been altered in any way or repaired by others and that factory sealed units are unopened (a service charge plus parts and labor will be applied to units defaced or physically damaged);
4. freight charges for the return of products to Valcom are prepaid;
5. all units 'out of warranty' are subject to a service charge. The service charge will cover minor repairs (major repairs will be subject to additional charges for parts and labor).

**This Limited Warranty is in lieu of and excludes all other warranties, expressed or implied and in no event shall Valcom, Inc. be liable for any anticipated profits, consequential damages, loss of time or other losses incurred by the buyer in connection with the purchase, operation, maintenance, installation, removal or use of the product. The maximum liability of Valcom under this warranty is limited to the purchase price of the specific Product covered by the warranty.**

**Disclaimer.** Except for the Limited Warranty provided herein, the product is provided "as-is" without any warranty of any kind whatsoever including, without limitation, any **WARRANTY OF MERCHANTABILITY, FITNESS FOR A PARTICULAR PURPOSE OR NON-INFRINGEMENT.**

This warranty specifically excludes damage incurred in shipment. In the event a product is received in damaged condition, the carrier should be notified immediately. Claims for such damage should be filed with the carrier involved in accordance with the F.O.B. point.

Headquarters:

Valcom, Inc.

5614 Hollins Road Roanoke, VA 24019-5056

Phone: (540) 563-2000 FAX: (540) 362-9800