

## VIP-851-25 & VIP-851-70/100 SIP 20W GATEWAY 25/70/100V

### INTRODUCTION

The VIP-851-25 and VIP-851-70/100 SIP 20W Gateways enable voice access to a single zone of one-way paging over an IP network, allowing page zones to be extended anywhere network connectivity is available. The VIP-851 can be programmed as a SIP (Session Initiation Protocol) device for connectivity to virtually any VOIP (Voice over IP) telephone system.

The VIP-851-25 has output connections for line level and 25-volt speakers only. The VIP-851-70/100 has output connections for line level and 25-volt, 70-volt or 100-volt speakers.

### SPECIFICATIONS

#### Features

- 1 Audio Input
- 2 Audio Outputs (VIP-851-25)
- 3 Audio Outputs (VIP-851-25/70/110)
- 1 Form C Relay
- 1 Contact Closure Input
- 1 SIP identity for registering to a VoIP telephone system
- Power over Ethernet 802.3at (PoE+) compatible
- Front panel activity LED
- Front panel PoE+ Fault indicator
- Front panel Supervision Fault indicator
- Provides line level audio for up to 40 Valcom one-way amplified speaker assemblies
- Contact closure or VOX operation of audio input
- Removable screw terminal connectors provided for audio and relay interfaces
- AUX input music mutes during page
- Barrel jack for optional DC power

#### Environment

Temperature: 0 to +40° C  
Humidity: 0 to 85% non-precipitating



VIP-851-25



VIP-851-70/100

#### Dimensions/Weight

- 1 Standard 19" Rack unit
- 1.75" H x 16.6" W x 4.8" D (4.4cm H x 42.2cm W x 12.2cm D)
- Weight:
  - VIP-851-25 2.00 lbs. (0.91 kg)
  - VIP-851-70/100 3.10 lbs. (1.41 kg)

#### Nominal Specifications

Input Impedance:	600 Ohms
Input Level:	-10dBm nominal
Voice Switch Sensitivity:	-21dBm
AUX Input Impedance:	8 to 600 Ohms
AUX Input Level:	-10dBm nominal
Output Impedance:	50 Ohms
Output Level:	- 10dBm nominal
Relay Current:	1 Amp @ 24VDC

#### Nominal Power Requirements

**Via rear panel barrel connector:**

Voltage:	24VDC
Current:	900mA

**Via 802.3at PoE+ Ethernet Switch:**

802.3at:	Class 4
----------	---------

# INSTALLATION

## FCC Information

This equipment has been tested and found to comply with the limits for a Class A digital device, pursuant to Part 15 of the FCC Rules. These limits are designed to provide reasonable protection against harmful interference when the equipment is operated in a commercial environment. This equipment generates, uses and can radiate radio frequency energy and if not installed and used in accordance with the instruction manual, may cause harmful interference to radio communications. Operation of this equipment in a residential area may cause harmful interference in which case the user will be required to correct the interference at his own expense.

## Precautionary Designations

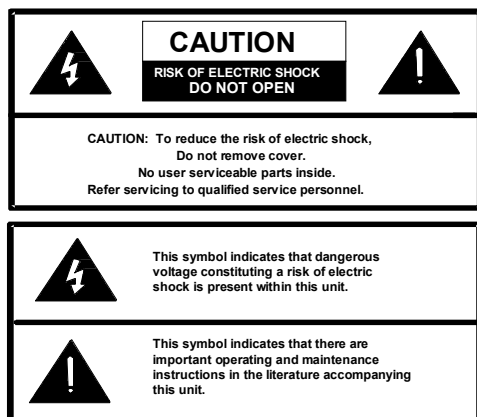

## Mounting

The VIP-851 is designed for rack mounting or wall mounting.

**Rack:** Secure mounting brackets to the VIP-851. Place the VIP-851 into a standard 19" rack and secure with proper hardware (not included).

**Wall:** Attach mounting brackets as shown in Figure 1, and secure to wall with proper hardware (not included).

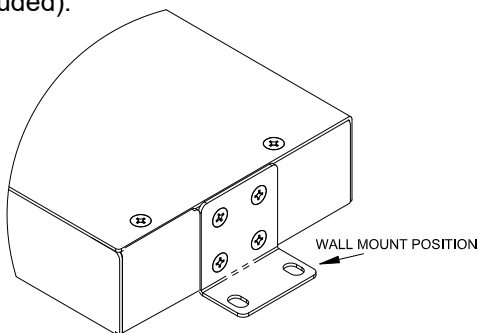

Figure 1. Mounting

## Power Connections

The preferred method of powering a VIP-851 is via a Power over Ethernet Plus (PoE+) switch meeting the 802.3at specification.

If the rear panel barrel connector is used for power, the preferred power supply is a Valcom VP-1124D.

Make all required signal connections before applying power to the unit. If powering via 802.3at, make sure all signal connections via the back panel are made then connect the VIP-851 to the Ethernet switch.

If power is supplied via the barrel connector, make sure all signal connections are secure. Attach the unit to the network via the front panel RJ-45 Ethernet connector. Apply power by plugging the power supply into the VIP-851 via the barrel connector on the rear of the VIP-851.

## Network Connection

The VIP-851 has one RJ-45 network connector on the front panel. Use a standard Ethernet patch cable to connect the VIP-851 to an Ethernet switch.

## Signal Connections

The VIP-851 has signal connectors on the rear panel:

- AUX audio input
- 1 Contact Closure input
- 2 Audio outputs (VIP-851-25)
- 3 Audio outputs (VIP-851-70/100)
- 1 Form C relay

**AUX Audio Input:** Line-level audio may be input via the rear panel screw terminal block labeled AUX. Nominal input impedance is 600 Ohms. Audio connected on AUX can be directed to the locally-connected speakers (Outputs connections) or across the network to other Valcom devices. Audio input is typically used for Background Music, and will be muted during a Page.

**Contact Closure Input:** Contact closure input labeled CC is provided for connecting an external contact (relay, switch, etc) to trigger actions in the VIP-851. The contact closure can be programmed to activate the AUX Audio Input to send audio across the network, or to remotely activate a relay on another Valcom device across the network.

**Audio Outputs:** Two or three audio outputs are available, depending on model. The VIP-851-25 provides two outputs, LINE and 25V. The VIP-851-70/100 provides three outputs, LINE, 25V and 70V or 100V. The LINE output provides a line-level signal suitable for driving up to 40 Valcom self-amplified speakers or other device requiring a line-level source. The LINE output may be used in combination with the 25V or 70/100V outputs. The 25V output provides up to 20 watts of audio power suitable for driving 25-volt speakers, with any combination of tap settings not to exceed 20 watts total. The VIP-851-70/100 provides additional connections for 70-volt OR 100-volt speakers, up to 20 watts total power. 70-volt speakers will connect to the COM (common) terminal and the 70V terminal. 100-volt speakers will connect to the COM terminal and the 100V terminal. Do not mix 70V and 100V speakers on the same VIP-851-70/100.

**Relay Channels:** Access to the form C relay is provided via a three pin screw terminal block. The relay is labeled K1. The relay is brought out on three terminals. The common contact is the middle terminal with the normally closed contact labeled NC and the normally open contact labeled NO. Relay contacts are rated for 1A @ 24VDC.

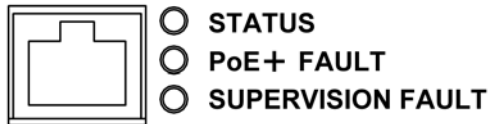

VIP-851 Front View

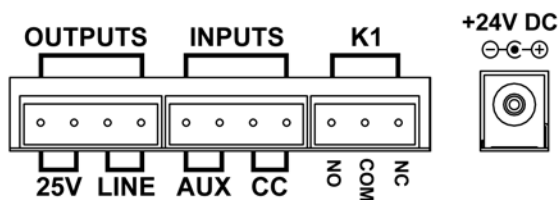

VIP-851-25 Rear View

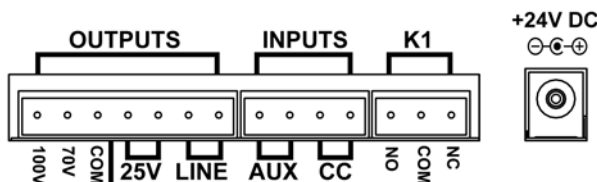

VIP-851-70/100 Rear View

## Setup

Information specific to your application will need to be programmed into the VIP-851 using a computer. The PC used for programming should be connected to the same subnet as the VIP-851. Setup will be done using the IP Solutions Setup Tool. Download the latest version of the free IP Solutions Setup Tool from the Valcom web site at [www.valcom.com/vipsetuptool](http://www.valcom.com/vipsetuptool).

## Status Indicator Lights

The VIP-851 has status indication lights on the front panel:

**STATUS:** Flashes during normal operation and solid during system startup.

**PoE+ FAULT:** Indicates the lack of correct PoE+ connectivity or an incorrect configuration of the current available to the port the VIP-851 is connected to.

**SUPERVISION FAULT:** Indicates a connectivity problem on either the LINE or 25V connections. The activity for this LED is configured using the IP Solutions Setup Tool.

LED OFF – No problem with any output.

LED ON SOLID – Problem with both 25V speaker connection AND Line connection.

LED FAST BLINK - (twice per second) Problem with 25V speaker connection only.

LED SLOW BLINK (on off for 2 seconds) Problem with Line connection only.

**Green LED:** (Link) Indicates Ethernet connection when illuminated.

**Yellow LED:** (Activity) Indicator flashes to indicate network activity.

## Factory Restore

Your VIP-851 ships with a switch accessible from the small hole on the front panel. The factory reset has 2 modes. Activate the modes by pressing and holding the switch using a paperclip or pin for a given number of seconds and then release the switch.

### Factory Reset:

- Hold the button in for 20+ seconds
- Network Reset actions, plus restores password to factory settings and overwrites configuration files to factory defaults.

### Network Reset:

- Hold the button in for 10-19 seconds
- Restores factory network settings to:
  - **IP address to 192.168.6.203**
  - **Netmask 255.255.255.0**
  - **Gateway 192.168.6.201**

## TECHNICAL ASSISTANCE

When trouble is reported, verify power is being supplied to the unit and there are no broken connections. If a spare unit is available, substitute a spare unit for the suspected defective unit.

Assistance in troubleshooting is available from the factory. Call (540) 563-2000 and press 1 for Technical Support or via email at support@valcom.com.

When requesting assistance, you should include all available information. General information and troubleshooting procedures are available on the Valcom website at www.valcom.com.

Valcom equipment is not field repairable. Valcom, Inc. maintains service facilities in Roanoke, VA. Should repairs be necessary, attach a tag to the unit clearly stating your company name, address, phone number, contact person and the nature of the problem. Send the unit to:

**Valcom, Inc.  
Repair & Return Dept.  
5614 Hollins Road  
Roanoke, Va. 24019-5056**

### VALCOM LIMITED WARRANTY

Valcom, Inc. warrants its products only to the original purchaser, for its own use, to be free from defects in materials and workmanship under conditions of normal use and service for a period of one year from the date of shipment. This Limited Warranty obligation shall be limited to the replacement, repair or refund of any such defective device within the warranty period, provided that:

1. inspection by Valcom, Inc. indicates the validity of the claim;
2. the defect is not the result of damage, misuse or negligence after the original shipment;
3. the product has not been altered in any way or repaired by others and that factory sealed units are unopened (a service charge plus parts and labor will be applied to units defaced or physically damaged);
4. freight charges for the return of products to Valcom are prepaid;
5. all units 'out of warranty' are subject to a service charge. The service charge will cover minor repairs (major repairs will be subject to additional charges for parts and labor).

**This Limited Warranty is in lieu of and excludes all other warranties, expressed or implied and in no event shall Valcom, Inc. be liable for any anticipated profits, consequential damages, loss of time or other losses incurred by the buyer in connection with the purchase, operation, maintenance, installation, removal or use of the product. The maximum liability of Valcom under this warranty is limited to the purchase price of the specific Product covered by the warranty.**

**Disclaimer.** Except for the Limited Warranty provided herein, the product is provided "as-is" without any warranty of any kind whatsoever including, without limitation, any **WARRANTY OF MERCHANTABILITY, FITNESS FOR A PARTICULAR PURPOSE OR NON-INFRINGEMENT.**

This warranty specifically excludes damage incurred in shipment. In the event a product is received in damaged condition, the carrier should be notified immediately. Claims for such damage should be filed with the carrier involved in accordance with the F.O.B. point.

Headquarters:  
Valcom, Inc.

5614 Hollins Road Roanoke, VA 24019-5056  
Phone: (540) 563-2000 FAX: (540) 362-9800