

V-2273

Sound360° 25/70 Volt Flat Panel Speaker

INTRODUCTION

The V-2273 Sound360° 25/70 Volt Flat Panel Speaker is suitable for large and/or noisy areas such as warehouses and manufacturing facilities. The innovative flat panel design provides 360-degree coverage in open spaces and produces less reverberation than cone-type speakers. Various power outputs can be easily selected on the speaker. The lightweight aluminum frame construction eases installation effort.

SPECIFICATIONS

FEATURES

- Variable wattage settings
- 25V, 70V or 4 Ohm input
- Removable input wiring connector
- 360° audio output

Nominal Specifications

- Frequency Response: 200Hz - 8kHz
- Dispersion: 360°
- SPL @ 1W, 1 Meter: 90 dB

Power Requirements

- Tap settings at 1, 2, 4, 8, 16 watts

Dimensions / Weight

- 29.25" W x 19.25" H x 3.0" D (4.5" D w/Wall Bracket)
(74.3 cm x 48.9 cm x 7.6 cm (11.4 cm w/Wall Bracket)
- 7.25 lb. (3.3 kg)

Environment

- Temperature: 0 to 40°C (32 to 104°F)
- Humidity: 0 to 85%, non-precipitating
- Indoor use only



Precautionary Designations

- **WARNING-To Reduce The Risk Of Fire Or Electric Shock. Do Not Expose This Apparatus To Rain Or Moisture.**
- **AVERTISSEMENT - Afin de réduire les risques d'incendie ou de décharge électrique, évitez d'exposer le système à la pluie ou à l'humidité.**
- **Apparatus shall not be exposed to dripping or splashing and no objects filled with liquids, such as vases, shall be placed on the apparatus.**
- **L'appareil ne doit pas être exposé à des égouttements et éclaboussures et aucun Objet Rempli de liquide, comme vase, ne doit être placé sur l'appareil.**

FCC Information

This equipment has been tested and found to comply with the limits for a Class A digital device, pursuant to Part 15 of the FCC Rules. These limits are designed to provide reasonable protection against harmful interference when the equipment is operated in a commercial environment. This equipment generates, uses and can radiate radio frequency energy and if not installed and used in accordance with the instruction manual, may cause harmful interference to radio communications. Operation of this equipment in a residential area may cause harmful interference in which case the user will be required to correct the interference at his own expense.

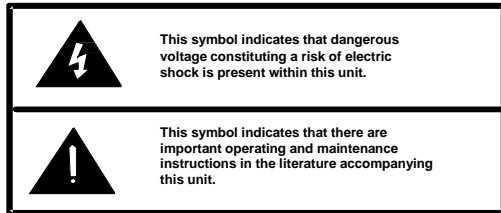
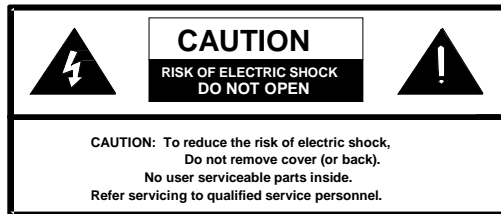

IMPORTANT SAFETY INFORMATION
CONSIGNES DE SÉCURITÉ IMPORTANTES

1. Read these instructions.
Lisez ces instructions.
2. Keep these instructions.
Conservez ces instructions.
3. Heed all warnings.
Respectez tous les avertissements.
4. Follow all instructions.
Suivez toutes les instructions.
5. Do not use this apparatus near water.
Ne pas utiliser cet appareil près de l'eau.
6. Clean only with dry cloth.
Nettoyer avec un chiffon sec.
7. Do not block any ventilation openings. Install in accordance with the manufacturer's instructions.
Ne pas bloquer les ouvertures de ventilation. Installer conformément aux instructions du fabricant.
8. Do not install near any heat sources such as radiators, heat registers, stoves or other apparatus (including amplifiers) that produce heat.
Ne pas installer à proximité de sources de chaleur telles que radiateurs, registres de chaleur, poêles ou autres appareils (y compris les amplificateurs) produisant de la chaleur.
9. Do not defeat the safety purpose of the polarized or grounding-type plug. A polarized plug has two blades with one wider than the other. A grounding type plug has two blades and a third grounding prong. The wide blade and the third prong are provided for your safety. If the provided plug does not fit into your outlet consult an electrician for replacement of the obsolete outlet.
Ne pas contourner le dispositif de sécurité de la fiche polarisée ou de mise à la terre. Une fiche polarisée possède deux lames dont une plus large que l'autre. Une fiche de terre a deux lames et une troisième broche de mise à la terre. La lame large et la troisième broche sont fournies pour votre sécurité. Si la fiche fournie ne rentre pas dans votre prise, veuillez consulter un électricien pour le remplacement de la prise obsolète.
10. Protect the power cord from being walked on or pinched particularly at plugs, convenience receptacles and the point where they exit from the apparatus.
11. Only use attachments/accessories specified by the manufacturer.
N'utilisez que des fixations / accessoires spécifiés par le fabricant.
12. Use only with the cart, stand, tripod, bracket or table specified by the manufacturer or sold with the apparatus. When a cart is used, use caution when moving the cart/apparatus combination to avoid injury from tip-over.
Utilisez uniquement avec le chariot, stand, trépied, support ou table spécifié par le fabricant ou vendu avec l'appareil. Quand un chariot est utilisé, Soyez prudent lorsque vous déplacez l'ensemble chariot / appareil pour éviter des blessures dues au renversement.
13. Unplug this apparatus during lightning storms or when unused for a long period of time.
Débranchez cet appareil pendant les orages ou lorsqu'il n'est pas utilisé pendant une longue période de temps.
14. Refer all servicing to qualified service personnel. Servicing is required when the apparatus has been damaged in any way. Such as when the power supply cord or plug is damaged, liquid has been spilled, objects have fallen into the apparatus or the apparatus has been exposed to rain or moisture and does not operate normally or has been dropped.
Confiez toute réparation à un personnel qualifié. Une réparation est nécessaire lorsque l'appareil a été endommagé de quelque façon. Par exemple lorsque le cordon d'alimentation ou la fiche est endommagé, du liquide a été renversé, si des objets sont tombés dans l'appareil ou le appareil a été exposé à la pluie ou à l'humidité et ne fonctionne pas normalement ou s'il est tombé.



INSTALLATION

Mounting

Note: There are four screws that protrude from the metal frame on the back of the speaker. The screws are installed at the proper depth during manufacturing and should not be adjusted or removed.

The V-2273 speaker can be mounted to a wall or attached to a structural beam. For wall or other surface mounting, use the bracket shown in Figure 1. The bracket is attached to the speaker for shipping; remove the bracket from the speaker before mounting. Pre-drilled holes in the bracket allow mounting to standard electrical boxes. Mount the bracket to the wall or electrical box first. After making the audio wiring connections, attach the speaker to the bracket using two screws at the top and two screws at the bottom of the frame. See Figure 1.

For mounting to a structural beam, two "C" clamps are provided with the speaker. Attach the C clamps to the speaker frame using the pre-threaded holes located near the corners of the frame. Then attach the clamp to a structural beam. The speaker can be mounted from the top, bottom or either side. See Figure 2.

For additional safety, unused mounting holes can be fitted with a ¼"-20 x 1" eyebolt and a cable attached to the building structure.

Input Connections

A metal cover with captive thumbscrew on the back of the speaker protects the input connections. Loosen the thumbscrew and remove the plate to access the wiring connections.

A removable wiring connector is inserted into the transformer board behind the cover plate. Pull the connector straight out away from the board to remove. Insert the 25V or 70V audio wires into the connector and secure by tightening the screws on the connector. Line up the wiring connector with the appropriate tap setting (wattage) desired, either in the 25V row or the 70V row (depending on amplifier used) and push the connector into the socket to make a good connection. If using a direct 4 Ohm amplifier output, insert the connector into the socket labeled 16 WATT 4 OHM. See Figure 3.

Note: The connector is shaped to only fit the socket on the board in one direction to maintain polarity. The transformer board socket is labeled for positive (+) and negative (-) connections. Make sure the connections maintain the correct polarity from the amplifier.

Valcom equipment is not field repairable. Valcom Inc. maintains service facilities in Roanoke, VA. Should repairs be necessary, attach a tag to the unit clearly stating your company name, address, phone number, contact person and the nature of the problem Sent the unit to:

Technical Assistance

Assistance in troubleshooting is available from the factory. Call (540) 563-2000 and press 1 for Technical Support or via email at support@valcom.com.

Valcom, Inc.
Repair & Return Dept.
5614 Hollins Road
Roanoke, VA 24019-5056

When requesting assistance, you should include all available information. It is strongly suggested that you go to the website and review the information at www.valcom.com.

Warranty

Warranty information may be found on our website at www.valcom.com/warranty

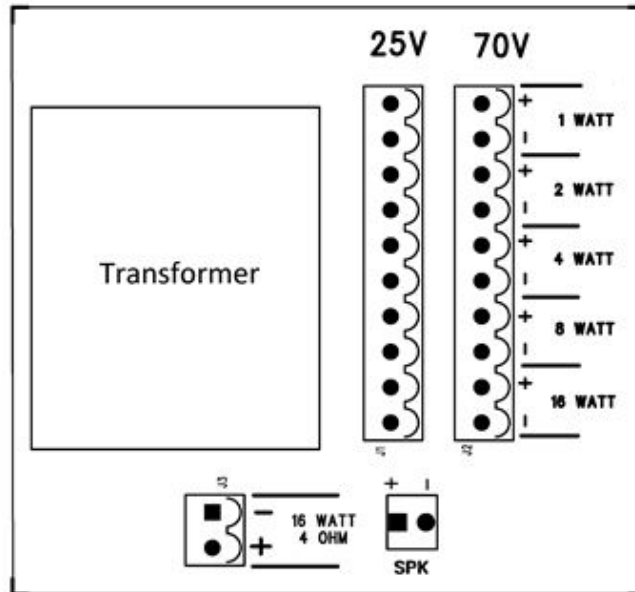

Figure 3: Connection

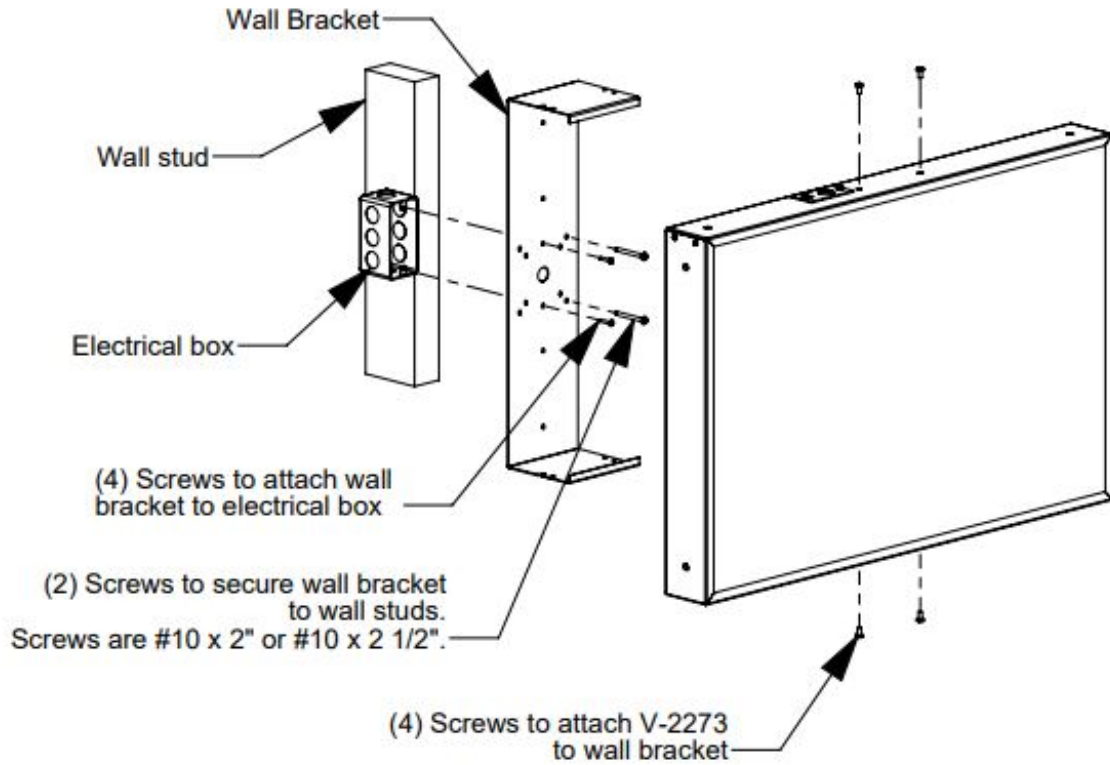

Figure 1: Wall or Surface Mounting

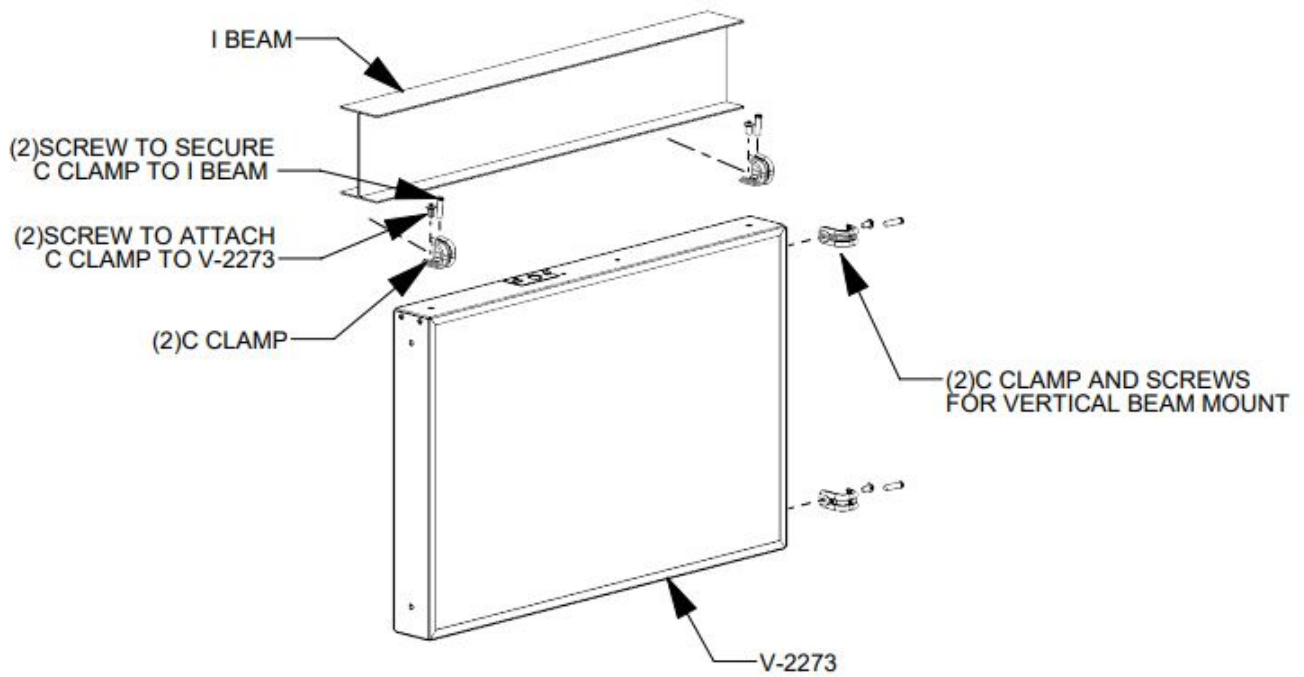

Figure 2: Beam Mounting