

## V-1097 SLIDE VOLUME CONTROL

### INTRODUCTION

The V-1097, Slide Volume Control, is a Valcom Volume Control Unit which can be mounted into a single-gang electrical box. This unit is compatible with all Valcom one-way and two-way speakers.

**NOTE: The V-1097 is not designed to connect directly to the output of high powered amplifiers.**

### SPECIFICATIONS

#### Applications

- To control volume of one-way amplified speaker assemblies in inaccessible areas
- To control large groups of one-way amplified speaker assemblies
- To control volume of Valcom talkback speakers

#### Dimensions/Weight

- 4.50"H x 2.75"W x 1.25"D  
(11.43cm H x 6.99cm W x 3.18mm D)
- Weight: .25 lbs. (0.11 kg)

#### Connections

Connections when using a One-Way Control Unit

(Refer to Figure 1)

- Connect wall mount volume control input tip and ring to desired zone output leads from page control.
- Connect wall mount volume control output tip and ring to speakers.

Connections when using a Talkback Control Unit  
(Refer to Figure 2)

- Connect wall mount volume control tip input terminal to tip output lead of talkback page control unit.
- Connect wall mount volume control tip output terminal to tip lead of talkback speaker.
- Connect ring output of talkback page control directly to ring of talkback speaker, (do not connect to V-1097).

#### Mounting

**Surface Mounting** - Mount standard single-gang electrical box. Install faceplate onto electrical box.

**Flush Mounting** - Install faceplate onto standard single-gang electrical box.

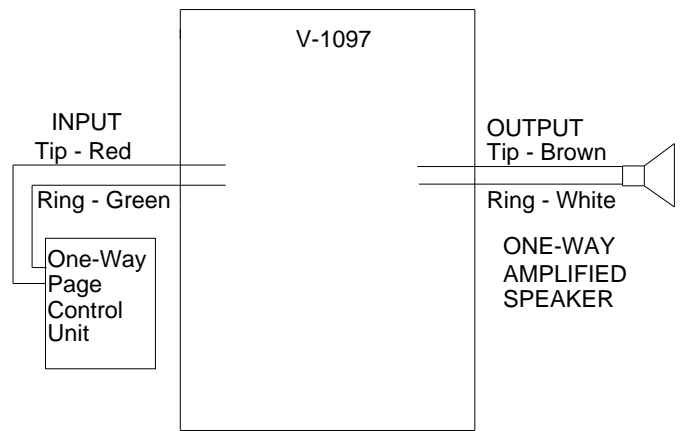

Figure 1. One-Way Connection

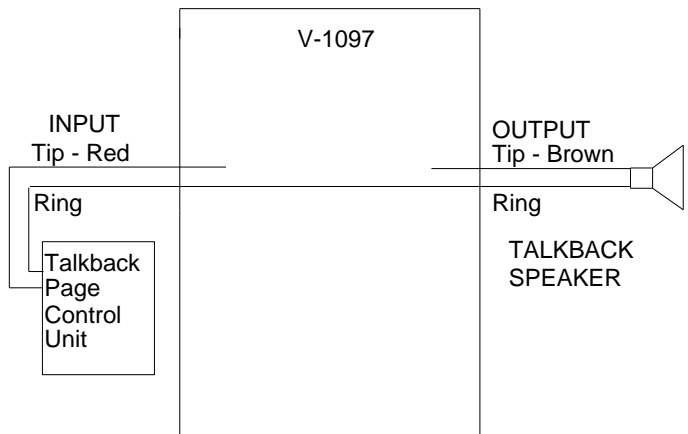

Figure 2. Talkback Connection

## TECHNICAL ASSISTANCE

When trouble is reported, verify the unit is properly connected and there are no broken connections leading to this unit.

If trouble still exists, using two clip leads, short tip in to tip out and ring in to ring out and test page. If the page works, replace the V-1097. If the system still does not work continue troubleshooting. If a spare unit is available, substitute the spare unit for the suspected unit.

If the trouble has not been located, refer to Table 1. Identify the symptoms and perform the actions indicated.

Assistance in troubleshooting is available from the factory. When calling, you should have a VOM and a test set and call from the job site.

Call (540) 563-2000 and press 1 for Technical Support or visit our website at <http://www.valcom.com>.

VALCOM equipment is not field repairable. Valcom, Inc. maintains service facilities in Roanoke, VA. Should repairs be necessary, attach a tag to the unit clearly stating your company name, address, phone number, contact person and the nature of the problem. Send the unit to:

**Valcom, Inc.**  
**Repair and Return Dept.**  
**5614 Hollins Road**  
**Roanoke, VA 24019-5056**

**TABLE 1 - TROUBLESHOOTING CHART**

| <b>Problems</b>             | <b>Possible Causes</b> | <b>Verifications</b>   | <b>Possible Solutions</b>                                   |
|-----------------------------|------------------------|--|---|
| No audio output to speaker. | Open input path.       | Place handset across V-1097 input terminals; No audio present. | Check cabling and cross-connections to V-1097.              |
|                             | Open output path.      | Place handset across speaker terminal; No audio present.       | Check cabling and cross-connections from V-1097 to speaker. |

### VALCOM LIMITED WARRANTY

Valcom, Inc. warrants its products only to the original purchaser, for its own use, to be free from defects in materials and workmanship under conditions of normal use and service for a period of one year from the date of shipment. This Limited Warranty obligation shall be limited to the replacement, repair or refund of any such defective device within the warranty period, provided that:

1. inspection by Valcom, Inc. indicates the validity of the claim;
2. the defect is not the result of damage, misuse or negligence after the original shipment;
3. the product has not been altered in any way or repaired by others and that factory sealed units are unopened (a service charge plus parts and labor will be applied to units defaced or physically damaged);
4. freight charges for the return of products to Valcom are prepaid;
5. all units 'out of warranty' are subject to a service charge. The service charge will cover minor repairs (major repairs will be subject to additional charges for parts and labor).

**This Limited Warranty is in lieu of and excludes all other warranties, expressed or implied and in no event shall Valcom, Inc. be liable for any anticipated profits, consequential damages, loss of time or other losses incurred by the buyer in connection with the purchase, operation, maintenance, installation, removal or use of the product. The maximum liability of Valcom under this warranty is limited to the purchase price of the specific Product covered by the warranty.**

**Disclaimer.** Except for the Limited Warranty provided herein, the product is provided "as-is" without any warranty of any kind whatsoever including, without limitation, any **WARRANTY OF MERCHANTABILITY, FITNESS FOR A PARTICULAR PURPOSE OR NON-INFRINGEMENT.**

This warranty specifically excludes damage incurred in shipment. In the event a product is received in damaged condition, the carrier should be notified immediately. Claims for such damage should be filed with the carrier involved in accordance with the F.O.B. point.

Headquarters:

Valcom, Inc.

5614 Hollins Road Roanoke, VA 24019-5056

Phone: (540) 563-2000 FAX: (540) 362-9800