

## V-9808 Vandal-Resistant Wall Speaker Faceplate INSTALLATION GUIDE

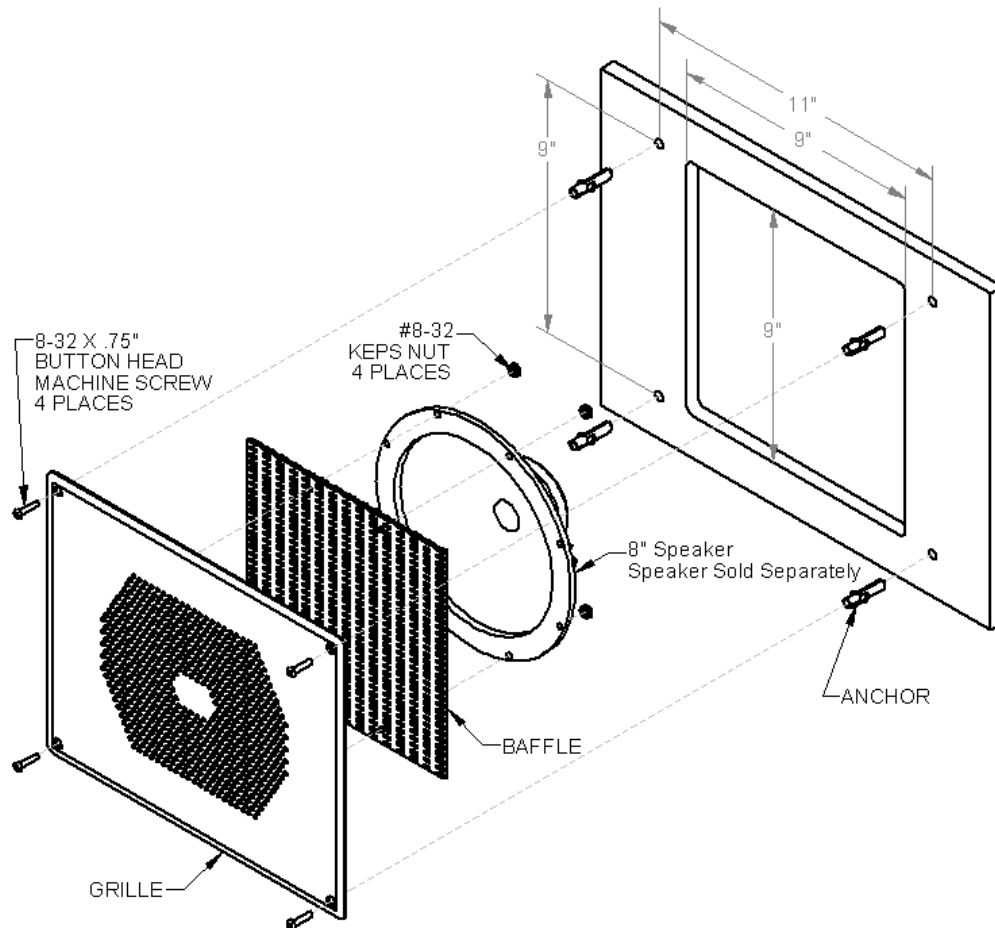

### DIMENSIONS/WEIGHT

- 10.00"H x 12.25"W x 16 GA  
(25.4cm H x 31.12cm W x 16 GA)
- 2.4 lbs. (1.1 kg)

## INSTALLATION

Remove the V-9808 Vandal Resistant Faceplate from the packing container. Hold the faceplate in the desired position on the wall and mark the location of mounting holes. Depending on wall construction type, prepare the mounting hole locations on the wall to securely attach the faceplate.

The V-9808 does not include a speaker. Mounting studs and nuts are provided on the back of the grille/baffle assembly to securely attach any Valcom 8" speaker. Remove the four nuts from the studs, align speaker mounting holes on the studs, then install and securely tighten the nuts.

Connect cable to speaker, and then use mounting hardware (not included) appropriate for the wall type to securely mount the enclosure to the wall.

## TECHNICAL ASSISTANCE

Assistance is available from the factory when problems are encountered. Call (540) 563-2000 and press 1 for Technical Support or visit our website at <http://www.valcom.com>.

Valcom equipment is not field repairable. Valcom, Inc. maintains service facilities in Roanoke, VA. Should repairs be necessary, attach a tag to the unit clearly stating company name, address, phone number, contact person and the nature of the problem. Send the unit to:

**Valcom, Inc.**  
**Repair and Return Dept.**  
**5614 Hollins Road**  
**Roanoke, VA 24019-5056**

### VALCOM LIMITED WARRANTY

Valcom, Inc. warrants its products only to the original purchaser, for its own use, to be free from defects in materials and workmanship under conditions of normal use and service for a period of one year from the date of shipment. This Limited Warranty obligation shall be limited to the replacement, repair or refund of any such defective device within the warranty period, provided that:

1. inspection by Valcom, Inc. indicates the validity of the claim;
2. the defect is not the result of damage, misuse or negligence after the original shipment;
3. the product has not been altered in any way or repaired by others and that factory sealed units are unopened (a service charge plus parts and labor will be applied to units defaced or physically damaged);
4. freight charges for the return of products to Valcom are prepaid;
5. all units 'out of warranty' are subject to a service charge. The service charge will cover minor repairs (major repairs will be subject to additional charges for parts and labor).

**This Limited Warranty is in lieu of and excludes all other warranties, expressed or implied and in no event shall Valcom, Inc. be liable for any anticipated profits, consequential damages, loss of time or other losses incurred by the buyer in connection with the purchase, operation, maintenance, installation, removal or use of the product. The maximum liability of Valcom under this warranty is limited to the purchase price of the specific Product covered by the warranty.**

**Disclaimer.** Except for the Limited Warranty provided herein, the product is provided "as-is" without any warranty of any kind whatsoever including, without limitation, any **WARRANTY OF MERCHANTABILITY, FITNESS FOR A PARTICULAR PURPOSE OR NON-INFRINGEMENT.**

This warranty specifically excludes damage incurred in shipment. In the event a product is received in damaged condition, the carrier should be notified immediately. Claims for such damage should be filed with the carrier involved in accordance with the F.O.B. point.

Headquarters:  
Valcom, Inc.  
5614 Hollins Road Roanoke, VA 24019-5056  
Phone: (540) 563-2000 FAX: (540) 362-9800